



Doosan Heavy Industries & Construction

Advanced Monitoring & Diagnostic Technology in NPPs

Doosan Heavy Industries & Construction

KookHun Kim, Ph. D

kookhun.kim@doosan.com

International Conference on Opportunities and Challenges
for Water Cooled Reactors in the 21st Century
Vienna, 27-30 October 2009

Monitoring & Diagnostic Technology

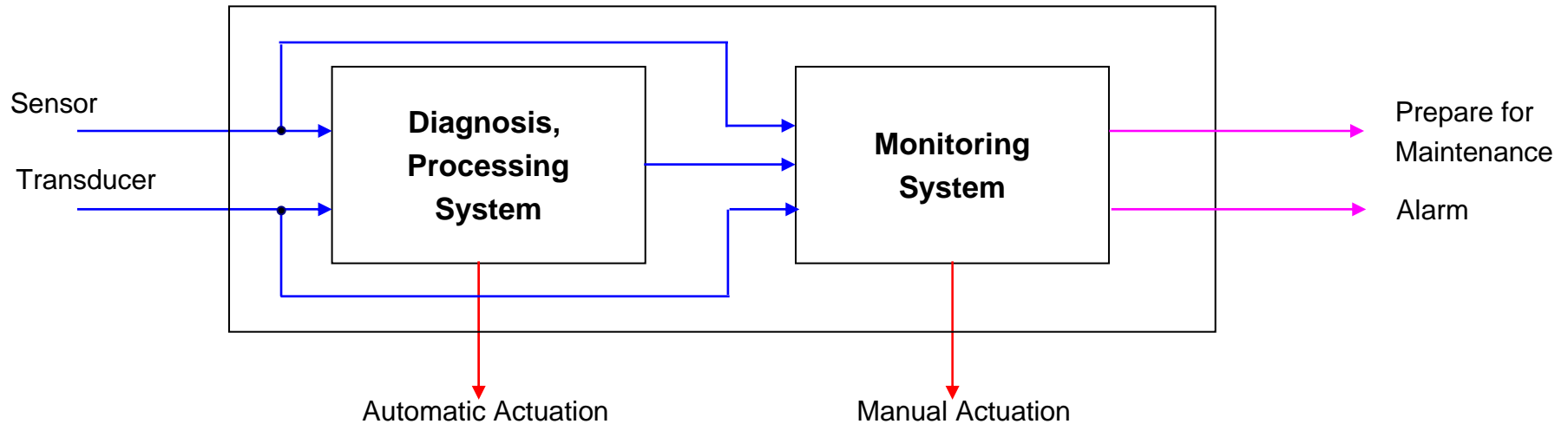

❑ purpose of diagnosis:

- maintenance and lifetime management
- manual actuation
- automatic actuation

❑ implementation method

- duplication of sensors, transducers, computers
- model based(analytical) diagnosis
- combined method(historical, expert system approach, duplication)

❑ response(diagnosis) time limit

- very fast
- relatively slow

Example : Protection system

Protection system based on redundancy diagnosis

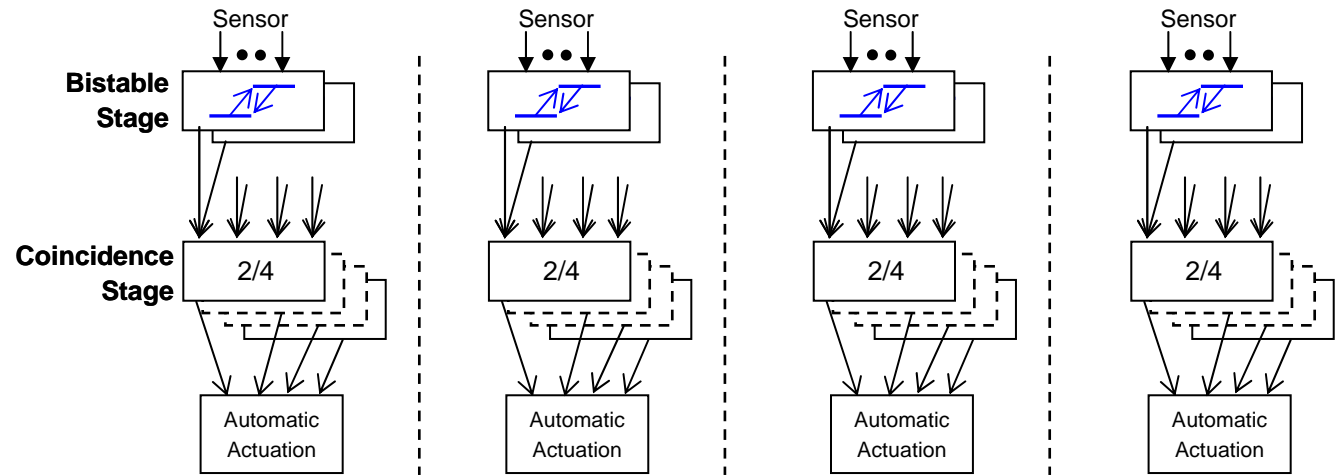

Is the simple structure with AMDT and S/W fault tolerance technology Possible?

