

Powerful Industrial Electron Accelerators Type ILU for Energy up to 10 MeV.

V. L. Auslender, V.V. Bezuglov, A.A. Bryazgin, V.A. Gorbunov, B.L. Faktorovich, E.N. Kokin, M.V. Korobeynikov, A.N.Lukin, I.G. Makarov, M.A. Tiunov, V. E. Nekhaev, A. D. Panfilov, V.M. Radchenko, A.V. Sidorov, E.A. Shtarklev, V.V. Tarnetski, V.O. Tkachenko, L.A. Voronin.
BINP SB RAS, Novosibirsk, Russia.

Abstract

The industrial electron accelerators type ILU are developed and produced by the Budker Institute of Nuclear Physics. The ILU accelerators are working in many countries in the industrial lines as well as in some research establishments starting from the beginning of 70-s. These machines are the pulse RF type accelerators with relatively low working frequency – 120MHz for ILU-6 and ILU-10 and 180MHz for ILU-8. Their energy range is from 0.8MeV (ILU-8) to 5MeV (ILU-10), beam power is up to 50kW.

The ILU machines are working in various technological processes – radiation modification of polymer tubes and films, polymer pipes for hot water supply, wires, cables, sterilization of single use medical products (syringes, hospital and operation gowns, sets for operations, etc.), decontamination of the medicinal raw.

The ILU accelerators are very compact machines because they do not need the big high pressure vessel filled with insulating gas. The height of the ILU-10 machine (with energy up to 5MeV) is less than 3 meters. The ILU-8 machine with energy range 0.8-1MeV can be installed inside the local shield with height of 3.24m. The local shield can be placed in the ordinary industrial shops.

The ILU accelerators are equipped with several beam extraction devices – linear scanner and scanners with 4 windows permitting to organize the irradiation of the long products (tubes, cables, wires, pipes) from 4 sides. The rewinding devices providing the twist-free transportation of the long products in the irradiation zone are also designed and produced by the Institute.

The new ILU-14 machine for energy range 7.5-10MeV is on the final stage of development. These machine is very good for radiation sterilization.

Average beam current (max), mA	20	30	15
Power consumption, kW	100	80	150
Accelerator weight, tons	2.2	0.6	2.9
Weight of local protection, tons	-	76	-

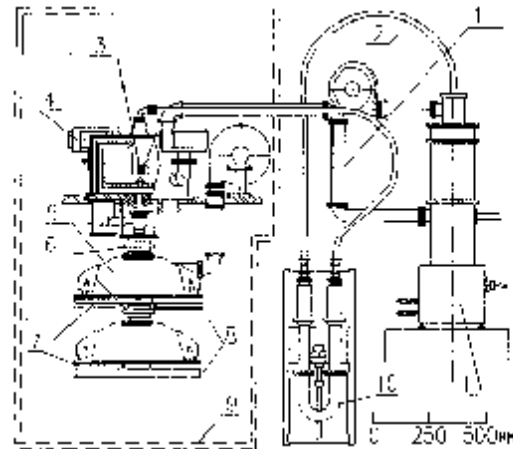

Figure 1: ILU-8 accelerator in local radiation shield.

GENERAL DESCRIPTION

Table 1 shows the basic parameters of the ILU-type accelerators produced by BINP [1-3].

Table 1: Basic parameters of the ILU-type accelerators

Parameters	ILU-6	ILU- 8	ILU-10
Energy of electrons, MeV	1.7-2.5	0.8-1.0	4-5.0
Average beam power (max), kW	20	20	50

The compact electron accelerator ILU-8 in radiation shield is shown in Fig. 1. Its energy range is 0.7-1 MeV, beam power is up to 20 kW. The main application field of this model is the irradiation of the wires, tubes and films. The radiation shield (realized as a box made of the steel plates) was designed with the shielded inputs and outputs for such long continuous products. The removable front wall serves as a door of the box. The height of the shield is little more than 3 m, its weight is about 76 tons. The thickness of radiation shielding in side walls part is 330 mm and in top is 240 mm, and it provides the complete protection from the radiation. The accelerator with this shield can be placed in most of the industrial shops without the modernization of the building.

The cavity is fed by the single staged self-excited RF generator. This generator is placed next to the local shield.

Main parameters of ILU-8 cavity are: diameter – 700 mm, height - 324 mm, resonance frequency – 176.2 MHz, accelerating gap – 36 mm, Q-factor – 24×10^3 , shunt impedance – 2.7 MOhm.

The model ILU-6 [1] is the most widely used accelerator in the ILU family. Its energy range is 1.5-2.5 MeV, beam power is up to 20 kW. This accelerator has rather good parameters at modest dimensions and is used for wide spectrum of technological processes.

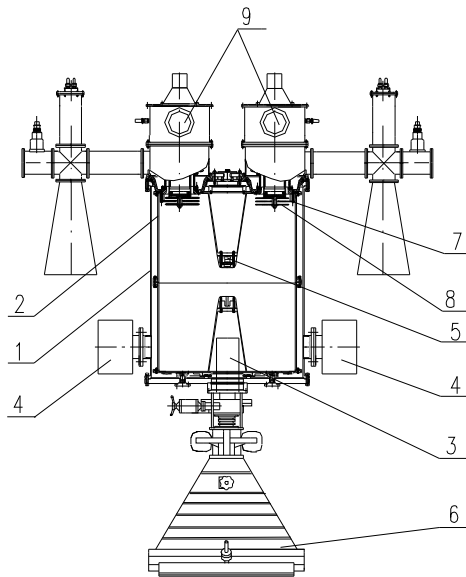

Figure 2: ILU-10 accelerator.

1 – vacuum tank, 2 – copper toroidal cavity, 3 – magnetic lens, 4 – ion pumps, 5 – electron injector, 6 – beam extraction device with linear scanning, 7 – coupling loop support, 8 – vacuum capacitor, 9 – RF generators.

The last machine is the ILU-10 accelerator (Fig. 2) developed on the same design concept as the ILU-6 accelerator. It was developed to work at energy of 5 MeV required for some technological processes. RF self-exciting generator based on powerful triode type GI –50A is installed directly on the vacuum tank.

In order to decrease high-frequency losses under the same with the ILU-6 resonator resonance frequency the accelerating gap length and total dimensions of the resonator was increased. The electron accelerator of ILU-10 type has two high-frequency generators of ILU-6 type, which operate in parallel for increasing of electron beam power.

Main parameters of the ILU-10 cavity are: diameter – 1000 mm, height – 1300 mm, resonance frequency - 115.9 MHz, accelerating gap length - 270 mm, Q-factor - 28×10^3 , shunt impedance - 8 MOhm.

APPLICATIONS OF THE ILU ACCELERATORS

The ILU accelerators are purposed for use in the industrial lines. Some ILU machines are working in the research organizations, and the main part of the machines are working in industry.

In the Budker Institute of Nuclear Physics one ILU-6 accelerator is used for research works for more than 40 years. Various irradiation technologies for industrial facilities were elaborated on this ILU-6 machine.

For years the main application of the ILU accelerators was the modification of the plastic products. The ILU accelerators in industry are treating the polymer insulation of the wires cables, cables and tubes to improve their characteristics. The pulse nature of the electron beam generated by ILU machines allows to easily realize the beam extraction through 4 windows (see Fig. 1). The extraction devices with 4 beam windows permit to organize the twist-free 4-sided irradiation of long products (cables, wires and tubes). Such irradiation scheme results in more efficient beam power utilization and greater maximum admissible insulation layer thickness comparing with 2-sided irradiation.

Now the ILU machines are treating the films and heat shrinkable polymer tubes. The new application is the treatment of polymer pipes for hot water supply.

The commercial irradiation of the various products on the ILU-6 machine in BINP started in the end of 80s. This machine is usually working with energy of 2.5 MeV. For most of the polymer products (having the density of 1 g/cm³) the penetration depth is 0.8 cm for single sided irradiation and 2 cm for two sided treatment (irradiation from one side, then turning of and irradiation from another side).

The amount and variety of the treated products were increased during the passed decades. The market of the single use medical devices was growing, and the first products irradiated by ILU-6 accelerator were syringes and blood exchange systems. Year by year the range of the treated products changed, and now most of the treated products are the single use medical products from the non-woven materials – sheets, sets for operations, operation gowns, etc.

The loading of the ILU-6 machine was constantly growing, and to the year of 2004 it worked for irradiation for 10-12 hours every day.

In 2004 the ILU-10 accelerator started to work for commercial irradiation in BINP. Its energy is 5 MeV, and so for most polymer products the penetration depth is 1.6 cm for single sided irradiation and 4 cm for two sided treatment.

The X-ray converter for ILU-10 machines was developed in BINP [4] to treat some products that have great thickness (initially it were frozen meat products).

In the year of 2008 both machines are constantly used in BINP for contract irradiation services. The ILU-10 is usually working at the energy of 5 MeV, and it is much more convenient for irradiation of various products than the energy of 2.5 MeV – usual working energy of the

ILU-6 machine. And now the ILU-10 machine is loaded by contract works for some hours every day. The loading of the ILU-6 machine is now much less – about 1-2 hours per day.

This situation clearly reflects the needs of the national economics and shows what machines are in need. The nearest to Novosibirsk industrial irradiation facility is not far – it is in the city of Kurgan, about 1000 km from Novosibirsk. The facility in Kurgan is working since 1992 [5], and it served the entire Siberian region.

Now there are more facilities in the Siberian region that render the irradiation services – 2 machines in BINP, Novosibirsk, one ILU-6 machine in Altay region, and one ILU-10 machine will start to work near Krasnoyarsk by the end of 2008.

The main products that were irradiated in BINP in 2008 were the medical products – medicinal raw, single use medical products like medical gowns, sets for operations, etc. The products are treated in the packed form – in the carton boxes containing the several sets of products.

The medicinal raw is treated in BINP since 1998, the initial load was less about 1 ton per month. There was a great increase in the years 2004 – 2007 – 7 times in 3 years. In 2007 the new facility with ILU-6 machine was put in operation in the Altay region, and amount of the medicinal raw treated in BINP decreased.

ILU ACCELERATORS IN THE WORLD

More than 30 ILU-type accelerators were installed in research organizations and industrial facilities in Russia, Ukraine, Belarus, Poland, Czechia, Hungary, Italy, Romania, Japan, China, South Korea, India and Cuba.

The ILU-6 accelerator installed in Russia in Izhevsk in 1993 was purposed for sterilization of the disposable syringes. Then for more than the decade the ILU accelerators were supplied only abroad – in China, Korea, Italy, USA, Japan.

In the recent years the Russian industry is demonstrating the stable growth, and the new technologies are also developing. The result is that the new ILU accelerators are installed in Russia.

ILU-8 machine was re-installed (the 20 year old machine was replaced by the new one) in 2005 in town of Himki, Moscow region, for treatment of the polymer films.

ILU-6 machine was installed in 2006 in Dimitrovgrad for cable treatment.

ILU-6 machine was installed in the Altay region in 2007 for sterilization of the medicinal raws.

ILU-10 accelerator is supplied in Krasnoyarsk region, it will be put into work this year. This machine is purposed mainly for plastic goods treatment, although the sterilization of the medical products is envisaged. Start of its work is planned by the end of 2008.

The ILU-8 machine will be supplied in 2009 for cable treatment in city of Cheboksary. The new technology for radiation modification of the fluoropolymers was elaborated.

The contract for ILU-10 machine is fulfilled and the machine is ready for installation in 2008. This machine is

purposed for treatment of the medicinal products in Novosibirsk. The mounting on site is postponed to the year of 2009.

ILU-10 machine is now supplied in Poland and will start to work in November 2008. This machine will treat the cable products and the polymer pipes for hot water supply.

The first experiments for irradiation of the polymer pipes by ILU-10 accelerator were carried out in Novosibirsk in the year of 1997, and there was the intention to produce these pipes in Novosibirsk. But this project was not realized that time.

During the last 6 years the demand for radiation sterilization of the medical products was constantly growing in Siberian region and everywhere in our country. More and more products are sterilized by electron beam.

The trend is that the industry needs the accelerators with energy 5-10 MeV and beam power of more than 30 kW (50-100 kW). The ILU-6 machine with energy up to 2.5 MeV not popular now. The ILU-10 machine with energy up to 5 MeV has the greater range of treated products, so it is better for industrial applications.

ILU-10 machine with energy up to 5 MeV much better suits for sterilization of various products than ILU-6 because of greater penetration depth. The computer simulation by the program GEANT and experimental measurements for single side irradiation give the following dependence for the penetration depth R (in cm) on energy (in MeV) for plastic products having density of 1 g/cm³ :

$$R = 0,405 * E - 0,161$$

So for energy of 2.5 MeV the penetration depth is about 0.8 cm, and for 5 MeV it is 1.6 cm.

For double sided irradiation the maximum admissible product thickness is to be multiplied in 2.5 times thus giving the value of 4 cm.

These figures are the basic stage for development of irradiation technology because this technology has to be elaborated and validated for every product to be treated.

NEW ACCELERATOR ILU-14

The prototype of high-power industrial electron accelerator ILU-14 has been successfully tested in pulsed mode at BINP SB RAS. The following parameters have been obtained:

Maximal accelerating voltage 7.5 MV

Beam pulsed current 600 mA at electron energy of 5 MeV

96% beam passing through the structure

Beam pulsed power 2.9 MW

Structure electron efficiency of 73% at electron energy of 5 MeV

Beam average power 37.5 kW at pulse repetition rate 33 Hz.

The results obtained proved the possibility to create the series of linear accelerators with electron energy up to 10 MeV and beam power up to 100 kW on

the base of RF modules designed by BINP. Rather narrow accelerated electron beam energy spectrum makes it possible to use the accelerators in both e-beam and X-ray modes that widen their field of application. Also, accelerators of that type may be a good replacement for ^{60}Co sources.

CONCLUSION

The industrial accelerators are demanded by industry and research institutions, and this demand in Russia is growing, and we are ready to meet the market needs.

The Budker Institute of Nuclear Physics is not restricting the activity only by supplying the accelerators. The important directions of work are researches connected with medical, biological and pharmacological applications of our accelerators. The new technologies developed in the Institute are later adopted by the industry.

The electron beam sterilization technology for disposal medical products is well studied and widely used in our country and abroad. This technology is good alternative to the gamma irradiators (Co and Cs isotopes sources). The ILU-10 accelerator can work with maximum energy of 5 MeV, it suits for the irradiation centres treating wide spectrum of goods. The energy of 5 MeV permits to treat variety of the products in the packed form – in the carton boxes containing the several sets of products.

The maximum beam power of ILU-10 accelerator is 50 kW, so the productive rate of the irradiation facility can be up to 300-700 kg per hour assuming the sterilization dose of 25 kGy.

REFERENCES

- [1] V.L. Auslender. "ILU-type electron accelerator for industrial technologies", Nuclear Instruments and Methods in Physical research, B 89 (1984) p. 46-48.
- [2] V.L.Auslender, R.A. Salimov, "Electron accelerators of INP SB AS USSR for national economy", Atomnaja energija, v.44, issue 5, 1978. – p. 403–408.
- [3] V.L. Auslender et al, "Electron Accelerator for Energy up to 5.0 MeV and Beam Power up to 50 kW with X-ray Converter", Problems of Atomic Science and Technology, 2004, №1, p.21-23.
- [4] M.F. Vorogushin, Yu.N. Gavrish, "Linear Electron Accelerators for Radiation Processes" ("Lineynye uskoriteli elektronov dlya radiatsionnyh protsessov", in Russian), report on ICAA'05, Sanct-Petersburg, Russia, October 2005.
- [5] V.L.Auslender, A.D.Bukin, L.A.Voronin, E.N.Kokin, M.V.Korobeinikov, G.S.Krainov, A.N.Lukin, V.M.Radchenko, A.V.Sidorov, Tkachenko, "Bremsstrahlung Convertors for Powerful Industrial Electron Accelerators", Radiation Physics and Chemistry. 13th International Meeting on Radiation Processing. (IMRP),v.71, issue 1-2 , September-October 2004, p.297-299.