

## The Heavy Ion Fusion Program in the USA

R.O. Bangerter 1), R.C. Davidson 2), W.B. Herrmannsfeldt 3),  
J.D. Lindl 4), B.G. Logan 1) & 4), and W.R. Meier 4)

- 1) Lawrence Berkeley National Laboratory
- 2) Princeton Plasma Physics Laboratory
- 3) Stanford Linear Accelerator
- 4) Lawrence Livermore National Laboratory
- 1), 2), 4) Heavy Ion Fusion Virtual National Laboratory

e-mail contact of main author: robangerter@lbl.gov

**Abstract.** Inertial fusion energy research has enjoyed increased interest and funding. This has allowed expanded programs in target design, target fabrication, fusion chamber research, target injection and tracking, and accelerator research. The target design effort examines ways to minimize the beam power and energy and increase the allowable focal spot size while preserving target gain. Chamber research for heavy ion fusion emphasizes the use of thick liquid walls to serve as the coolant, breed tritium, and protect the structural wall from neutrons, photons, and other target products. Several small facilities are now operating to model fluid chamber dynamics. A facility to study target injection and tracking has been built and a second facility is being designed. Improved economics is an important goal of the accelerator research. The accelerator research is also directed toward the design of an Integrated Research Experiment (IRE). The IRE is being designed to accelerate ions to  $>100$  MeV, enabling experiments in beam dynamics, focusing, and target physics. Activities leading to the IRE include ion source development and a High Current Experiment (HCX) designed to transport and accelerate a single beam of ions with a beam current of approximately 1 A, the initial current required for each beam of a fusion driver. In terms of theory, the program is developing a source-to-target numerical simulation capability. The goal of the entire program is to enable an informed decision about the promise of heavy ion fusion in about a decade.

### 1. Introduction

Interest in inertial fusion energy (IFE) research in the USA has increased during the past several years. The inertial fusion community has a new development plan with explicit milestones leading to a demonstration power plant (IFE Demo). The outline of the new plan is shown in FIG. 1 on the following page. In developing this plan, the community started from the goal of an IFE Demo in approximately 2025 and worked backward to determine what was necessary to achieve this goal. The plan preceding the IFE Demo has four phases: Concept Exploration, Proof of Principle, Performance Extension, and Fusion Energy Development. There is a parallel plan for magnetic fusion that has the same four phases. For each phase there is a cost goal. These cost goals are based on judgements about the funding environment in the USA and on the value of fusion relative to other long-term energy sources. There is a decision point at the end of each phase. See FIG. 1 on the following page for these decision points and their approximate dates.

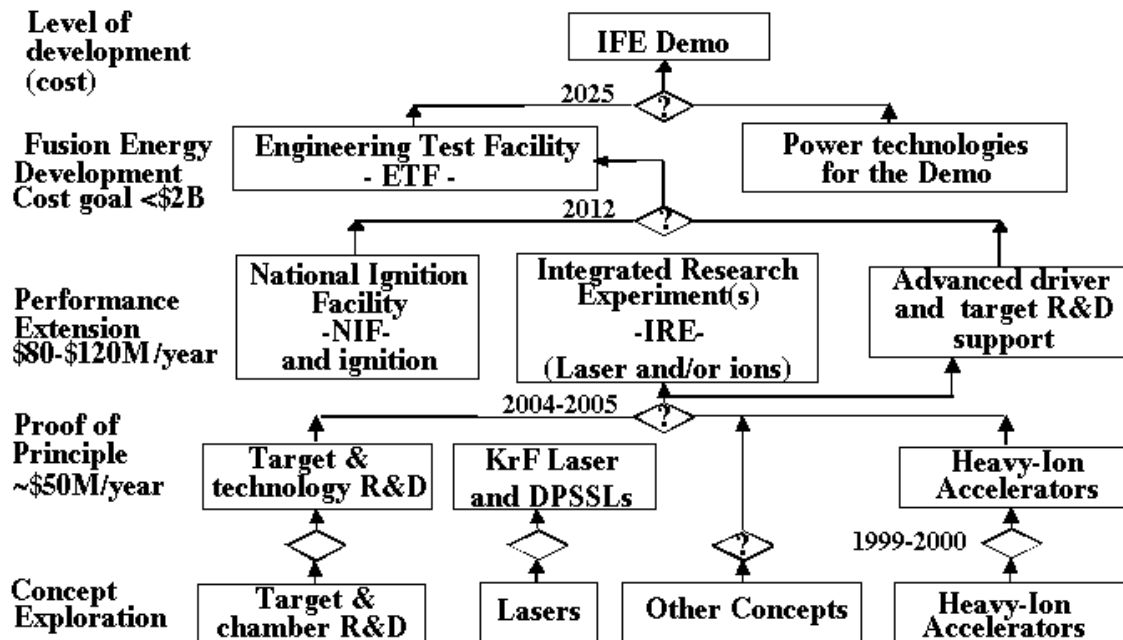

FIG. 1. A graphical representation of the new national IFE program plan.

Three IFE drivers have advanced from the Concept Exploration level to the Proof of Principle (PoP) level: heavy ion accelerators, KrF lasers, and diode pumped solid state lasers. An important goal of the PoP phase of the program is to obtain enough information to build a scaled driver called the Integrated Research Experiment (IRE). The IRE is not expected to be large enough to ignite a target but it must be large enough to resolve all issues associated with the driver. The IRE together with the target physics information from the Department of Energy's Defense Inertial Confinement Fusion Program, and other target and chamber research programs worldwide, will provide the basis for the construction of an Engineering Test Facility (ETF). In the USA, the National Ignition Facility (NIF) is a cornerstone of the Defense ICF Program. Although the NIF has recently experienced delays, it should nevertheless provide data in time for the decision to proceed with the ETF. The ETF will be the first IFE facility to produce high levels ( $> 100$  MW) of average fusion power. The ETF and continuing research on other fusion power technologies such as target fabrication and chambers will provide the basis for the Demo.

The remainder of this paper will discuss only heavy ion fusion. In addition to the role that heavy ion fusion plays in the plan outlined (*see FIG. 1 above*), heavy ion fusion is, in a broader context, also part of, and fully consistent with, the Restructured U.S. Fusion Program. The mission of the Restructured Fusion Program [1] is to:

“Advance plasma science, fusion science, and fusion technology – the knowledge base needed for an economically and environmentally attractive fusion energy source.”

Developing a system that is economical in terms of both research costs and the ultimate cost of electricity is an important challenge for all approaches to fusion energy. Heavy ion fusion is no exception but it has some unique features. The cost of high energy accelerators increases slowly with increasing pulse repetition rate. The reasons for this scaling are straightforward. It requires a certain investment in beam transport systems, acceleration systems, control systems,

etc. to produce enough energy and power per pulse to ignite an inertial fusion target. Most of these systems can operate at high pulse repetition rates (substantially greater than 10 Hz). To increase the repetition rate of an accelerator, it is necessary only to increase the systems that provide the power to the accelerator (and pay additional attention to issues such as cooling). Because of this characteristic, heavy ion fusion is projected to have excellent economics at large plant capacity. For example, one could drive four, 1 GW fusion chambers with a single accelerator. The challenge (and goal) is to develop accelerators and other power plant components that give good economics at low plant capacity. Low cost for an IRE and an ETF are also important goals.

The current (PoP) phase of the program has several tasks. These include expanded research efforts in target design, target fabrication and injection, chamber dynamics, and accelerator research. This increased effort requires increased funding. The Department of Energy and Congress have supported increased funding. The total funding for IFE research has increased from approximately \$7 M in FY1998 to nearly \$20 M in FY1999 and about \$28 M in FY2000. As this paper is being written, there is still uncertainty regarding the budget for FY2001. Institutional participation, particularly in the chamber and target fabrication areas, has increased. To manage the increased funding and increased institutional participation efficiently, a Virtual National Laboratory (VNL) for Heavy Ion Fusion has been created. The term "virtual" refers to the fact that the VNL does not exist as a single set of buildings at a single site. Moreover the individual people working in the VNL remain employees of the laboratories that created the VNL. The VNL is a mechanism for coordinating heavy ion fusion research. It combines the three largest accelerator research programs (LBNL, LLNL, and PPPL) under a single management. Although they are not officially members of the VNL, there is important participation from SNLA, NRL, SLAC, the University of Maryland, the University of Missouri, MIT, Advanced Magnet Laboratory, Advanced Ceramics, Allied Signal, National Arnold, MRC, and General Atomics. Another virtual laboratory, the Virtual Laboratory for Technology (VLT), manages the research in the chamber and target fabrication areas. The VLT also manages fusion technology research. VLT inertial fusion participants include LANL, INEEL, UCB, UCLA, UCSD, LLNL, Georgia Tech, General Atomics, and the University of Wisconsin. Many of these institutions are also involved in magnetic fusion research. This organizational arrangement promotes cross-fertilization between magnetic and inertial fusion.

## **2. Program Elements, Issues and Progress**

As noted above, the goal of the program is to develop a heavy ion fusion system that is economically and environmentally attractive. Achieving this goal requires improved science and technology in several areas. This section lists these areas, describes the principal issues and reports recent progress.

### **2.1 Target Design**

The target design effort aims to minimize the energy and power requirements require new and to maximize target energy gain. It also aims to maximize the allowable focal spot size and to use materials that have good fabrication and environmental characteristics. Lower energy and power requirements lead to lower accelerator cost. Larger focal spot sizes also lead to lower accelerator cost. Moreover, they reduce the size and cost of the final focusing system (essentially higher  $f$  number systems) leading to reduced beam entry port size, reduced activation, and longer life. Unfortunately, for fixed target gain, reduced target energy requirements imply reduced target energy yield, leading to an increased repetition rate for a given plant capacity. This situation puts more stringent requirements on the cost of each individual target. Furthermore, smaller targets typically require better precision in fabrication, injection, and tracking.

There has been very good progress in target design [2]. Several years ago the best U.S. target designs required 6 MJ of beam energy to produce a target gain of approximately 70. These target designs required elliptical focal spots with semi-axes of 1.8 mm and 4.15 mm. More

recent designs, according to 2-dimensional numerical simulations, require 1 to 3 MJ of beam energy and have predicted gain between 90 and 130. The improvements in energy and gain have been obtained by improving the target coupling by reducing the size of the hohlraum relative to the size of the capsule. While this strategy is effective from a target standpoint, it requires small focal spot sizes (1 mm by 2.8 mm for a 3 MJ design) leading to increased demands on beam brightness and focusing systems. Efforts are now underway to design targets that allow larger focal spots, but it is likely that smaller focal spots will always lead to smaller energy requirements and larger gain – at least for hohlraum targets. For example, one recent design having a 3.8 mm by 5.4 mm spot size requires nearly 7 MJ of energy and has a predicted gain of 60.

## **2.2 Chamber Research and Other Associated Technologies**

Many types of chambers have been considered for heavy ion fusion: dry walls, wetted walls, walls protected by sprays or granules, and walls protected by thick liquid jets or layers. While several of these systems may be technically feasible, the systems with thick liquid walls have a number of advantages and are currently receiving the most emphasis. In these systems, the fluid serves as the coolant and the tritium-breeding medium. Perhaps more importantly, it protects the wall from neutrons leading to low activation and long life. Some designs have a predicted life equal to the plant life.

The HYLIFE II chamber design [3] is a recent example of a chamber with thick liquid wall protection. It uses oscillating fluid jets to form a pocket or cavity for the target. It also uses crossed jets to protect the conductors of the final focusing elements. For both applications it is desirable to have jets with smooth surfaces. A significant number of droplets or spray associated with the jets could interfere with beam propagation. Moreover, the jets used to protect the conductors of the focusing elements should be as close to the beams as possible to minimize the flux of neutrons entering the beam ports. It has not proved easy to make smooth, high-velocity jets, particularly if they are oscillating. Peterson and his collaborators at UC Berkeley have recently produced smooth, oscillating jets of water scaled hydrodynamically to be similar to jets of lithium containing fluids that might be used in a power plant [3]. Producing smooth jets requires careful conditioning of the fluids as they enter and pass through the nozzles. There is also important research in liquid wall protection at UCLA [4] and Georgia Tech. [5].

Target injection and tracking are important technologies that must be developed for a power plant. Petzoldt [6] built a simple air rifle capable of accelerating surrogate targets to a velocity of approximately 100 m/s. Photodiodes measure the transverse position of the target about 1 m beyond the end of the barrel. The position of the barrel and the measurement by the diodes are used to predict the target position in a chamber located approximately 2 m from the diodes. This prediction is compared to a measured position in the chamber, again made with photodiodes. The rifle itself was not particularly accurate. The measured position of the target in the chamber varies by several mm; however, the rms difference between the predicted position and the measured position is less than 100 microns. This precision extrapolates to adequate precision for indirectly driven targets in a power plant where the injection distances are longer than the 2 m in Petzoldt's experiments. General Atomics is now designing a new system.

The Defense Programs Inertial Confinement Fusion Program supports a substantial level of research in target fabrication. It is likely that some of the fabrication techniques that have been developed, e.g., beta layering and diffusion filling, will also be useful for fusion power production. However, power production imposes some additional constraints. The targets must survive the acceleration associated with injection. They must survive in the chamber environment. They must be made of materials that are inexpensive, environmentally acceptable, extractable, and in some cases recyclable, from the liquids and gases flowing through the chamber, and chemically compatible with the rest of the chamber system; and they must be mass produced at low cost.

Target survival is a particularly important issue for direct drive. If the target is injected too slowly, the high temperature in the reactor (usually  $> 500$  C) will destroy the integrity of the cryogenic fuel layer. If the target is injected too rapidly, the aerodynamic drag in the gas into the chamber will also produce too much heat. Calculations and experiments addressing this issue are in progress. Although indirectly driven targets are thermally protected by the hohlraum, they have more issues than directly driven targets in terms of materials that are environmentally and chemically acceptable. Some of the issues associated with target materials, fabrication, and injection have been discussed by Latkowski, et al. [7] and Schutz, et al. [8].

### 2.3 Accelerators and Beam Physics

There are a number of important accelerator issues. Those who are not familiar with the heavy ion fusion program might suppose that the accelerator issues have already been resolved at the large accelerator facilities for high energy physics and nuclear physics. While these accelerators provide invaluable information and a strong technology base for heavy ion fusion, they do not answer all important beam dynamics issues for fusion. To understand this point, it is useful to think of an ion beam as a nonneutral plasma. It is necessary to confine this plasma within a vacuum channel as it passes through the accelerator. As in magnetic fusion, the plasma is confined by applied fields. In most conventional accelerators, the beam plasma frequency is small compared to the betatron frequency (the frequency of oscillation of the particles in the applied fields). In fusion accelerators, the beam plasma frequency must be comparable to the betatron frequency in order to provide enough beam power to ignite the targets. Stated differently, the ion current and space charge effects are larger in fusion accelerators. The high current can be particularly important as the beam propagates from the final focusing lenses across the chamber to the target.

It is well known that high energy particle beams are commonly focused to spots that are much smaller than those required for fusion (of the order of one micron in existing lepton colliders). The ability of a beam to be focused is determined not only by its current but also by the phase-space volume that it occupies. In accelerator terminology, the phase-space volume is referred to as emittance. (Technically the emittance is usually the phase-space area in one of the three orthogonal directions so the 6-dimension phase-space volume is proportional to the product of three, 2-dimensional emittances.) Fusion requires not only a small focal spot but also a sufficient number of ions to ignite a target. For this reason, an important quantity of interest is the beam brightness, basically the phase-space density. Obtaining high power and a small focus requires adequately low current and adequately high brightness. One can reduce the current to acceptable levels by accelerating the beams to high kinetic energy, of the order of 10 GeV. Alternatively one can attempt to neutralize the beams as they travel through the chamber. In the USA we propose to use induction accelerators for fusion. It appears that the economic optimum for these machines corresponds to an energy less than 10 GeV so that neutralization in the chamber is desirable.

The fraction of the accelerator aperture (vacuum pipe) that can safely be filled with beam is another important quantity. For a fixed aperture and applied focusing field, the current (and power) that can be transported in a single beam is proportional to the square of the beam radius. For economics and efficiency it is desirable to maximize the ratio of the beam radius to the aperture (sometimes called the fill factor). The achievable fill factor is related to beam edge effects or beam "halo". Understanding these effects and their relationship to fill factor and emittance is an important goal.

Finally, low accelerator cost requires improvements in technology.

Accelerator research at the PoP level has been underway for about two years. The PoP phase of the program is built on the theory, simulation, and experiments of the last two and a half decades. During this period, the program performed a number of small experiments that, in a scaled sense, established the beam physics and demonstrated the beam manipulations needed for a full-scale driver. The larger experiments, e.g., the Single Beam Transport Experiment (SBTE) and the Multiple Beam Experiment with 4 Beams (MBE-4) were performed at Berkeley

but there have also been important experiments at Brookhaven, Argonne, Livermore and the University of Maryland. These experiments have shown that it is possible to produce, transport, and accelerate heavy ion beams with more than adequate brightness for fusion applications [9]. The scaled experiments have been in a driver-relevant parameter regime in terms of important dimensionless parameters such as the ratio of betatron frequency to the periodicity of the transport (confinement) fields in the accelerator and the ratio of the beam plasma frequency to the betatron frequency. These experiments typically transported and accelerated approximately 10 mA of current per beam. The corresponding current in a full-scale driver is expected to be of the order of 1 A per beam at low energy end of the accelerator, increasing to the order of a 1kA per beam at final focus. There are important, unresolved issues associated with the absolute scale of the current. The experiments with the LBNL, 2-MeV injector, delivers approximately 1 A of beam current, to allow us to address the issues associated with the higher currents. These issues include are expected to involve the interaction of the beam halo with the walls of the transport channel. Other issues associated with the focusing and transport of high-current beams in a fusion chamber environment also remain largely unexplored experimentally.

Prior to 1996, we had planned to build ILSE (Induction Linac Systems Experiment, later called Elise) [10]. Instead, plans were changed, and we initiated a series of scaled experiments designed to address all systems and beam manipulations needed for a full-scale driver. These experiments are now completed. The experiments were driver-like in terms of key dimensionless parameters mentioned above but not driver-scale in parameters such as total ion kinetic energy or line charge density. Recent experiments have addressed transverse beam combining, ballistic focusing with and without neutralization, channel transport, and self-pinch propagation in the chamber. The scaled experiments are described in detail in references [9] and [11]. Briefly, these experiments have validated analytical and numerical predictions of beam behavior. They have served to benchmark our simulation tools, and, as noted above, they have shown that it is possible to produce, transport, and accelerate beams having more than adequate brightness for fusion applications. The injector research is the one major exception to the philosophy of scaled experiments. The present 2-MV injector produces a single driver scale beam (line charge density of the order of  $10^{-7}$  C/m or 300 to 800 mA of potassium or cesium).

Although the experiments have generally validated theoretical expectations, they have also uncovered some areas that need additional research. For example, the reliability and lifetime of our ion sources require improvement. The injector beam optics must also be improved, and it would be desirable to reduce the cost and size of our injector systems. In addition, we believe that it is necessary to perform new experiments in acceleration, transport and focusing of beams, having driver-scale line charge density, before proceeding to the IRE. Our plans to perform such experiments are described in Section 3.

The theoretical goal is source-to-target simulation of the entire accelerator. We are using and developing three classes of computer codes. (1) Particle-in-cell codes. Our main code for studying beam dynamics in the accelerator itself is WARP, a 3-dimensional code with a detailed description of the lattice. For beam propagation in the target chamber, our main codes are the electromagnetic codes BIC, BPIC, and LSP. The first two have been developed primarily at Berkeley and Livermore while LSP has been developed by Mission Research Corporation. Recent results are encouraging. They indicate that neutralization by plasma and electrons allows kinetic energies less than 10 GeV. In some example calculations, the self magnetic forces of the beam produce a smaller focal spot than one would expect from purely ballistic focusing. (2) Codes that evolve the particle distribution function  $f$ . BEST, developed at Princeton, is a 3-dimensional delta- $f$  code that has been used to investigate the nonlinear dynamics of stable beam propagation, and the two-stream instability [12]. SLV (Semi-Lagrangian Vlasov) evolves  $f$  on a 4-dimensional grid (two spatial dimensions and two momenta). This code has proved to be particularly useful for studying processes such as beam halo formation because, unlike the particle-in-cell codes, it is not limited by the statistics of small numbers in regions where there are few particles. (3) Codes that follow moments of  $f$ . These codes run relatively rapidly and are used for synthesis of lattices and waveforms. CIRCE, a code originally developed at Livermore to study induction recirculators is one example of this class of codes.

The status of the codes and some recent results have been reported by Friedman, et al. [13]. Current code development efforts focus on improved models for cavity impedance and the beam-beam interaction in multi-beam accelerators.

### 3. Plans

The goals of each phase of the program are determined by working backward from the ultimate goal of an IFE Demo. Consequently, before describing our near-term PoP goals, we give a brief description of the IRE goals.

The IRE must address a wide variety of scientific issues. Some of these issues are associated with high intensity beam physics in the accelerator itself. Here the IRE must determine and, if possible, expand the limits on long-term transverse and longitudinal beam dynamics. It must measure transverse and longitudinal emittance growth. For example it must determine under what conditions there are longitudinal instabilities. If these instabilities are deleterious, it must provide a vehicle to develop countermeasures, e.g., feedback stabilization. The IRE must allow us to study halo formation and its effect on required beam clearance. It must allow us to study effects associated with high intensity beams such as the presence of unwanted electrons. It must also allow us to study focusing and beam propagation in chambers. Finally, the IRE must be capable of addressing remaining target physics issues such as validating our understanding of the beam-plasma interaction. Additionally, it would be desirable to be able to study target physics issues such as fluid instabilities in direct drive and other topics in high energy density physics.

These general goals in accelerator physics, chamber propagation, focusing physics, and target physics lead to quantitative IRE requirements. For example, to study long-term transverse and longitudinal beam dynamics requires hundreds of lattice periods and enough beam current ( $> 100$  A) to load the induction modules and pulsers. It appears difficult to do definitive transport and focusing experiments at kinetic energies less than 100 MeV. The criteria for studying the beam-plasma interaction are a beam plasma frequency and a plasma temperature within a factor of a few of the beam plasma frequency and temperature at the focus of a full-scale driver. These criteria require the IRE to have a focused intensity  $> 3 \times 10^{16}$  W/m<sup>2</sup> and a total beam energy of several kilojoules – all within a specified cost goal (*see FIG. 1 shown on second page*). This cost goal corresponds to a total cost of the accelerator itself of approximately \$150 M. It is not possible, at the present time, to build such a machine at this price so technology improvement is an important part of the PoP phase of the program.

We are exploring IRE options producing from 30 to 300 kJ of energy. One specific example produces 30 kJ of energy by accelerating K<sup>+</sup> ions to 200 MeV. This example has 32 beams and a length of approximately 300 m. We have not yet performed a cost estimate for this design (*see FIG. 2 below*).

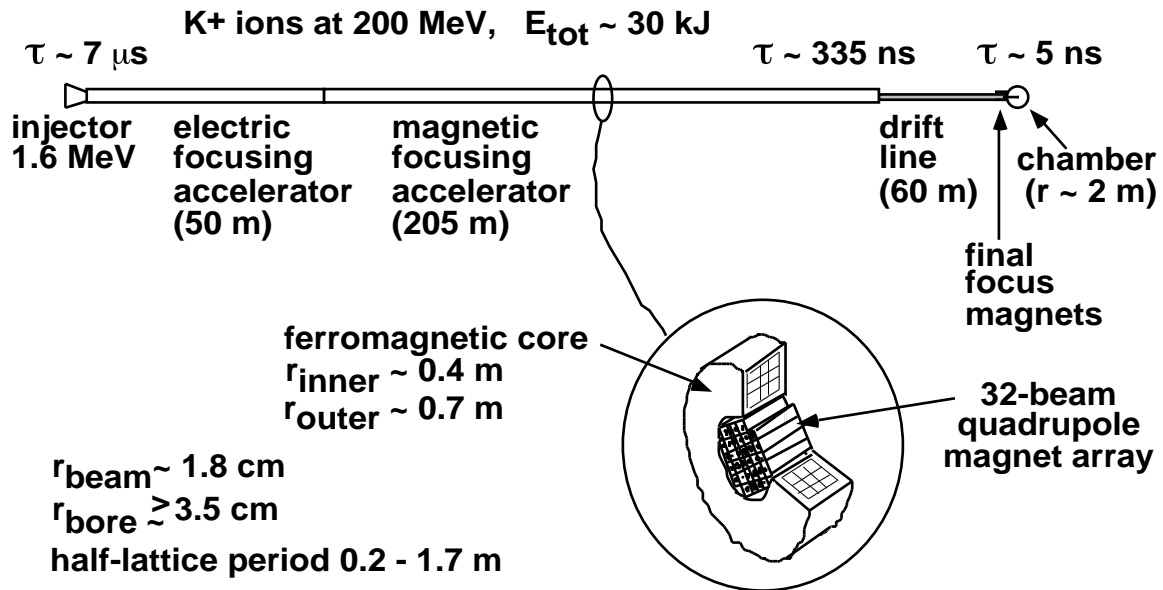

FIG. 2. One possible example of an IRE.

In order to be in a position to build the IRE, and to obtain the widespread support necessary to get such a project approved, we have adopted a number of aggressive research goals:

1. Source-to-target simulation of full-scale drivers and the IRE.
2. Development of driver-scale ion sources and injectors. As noted above, we must improve the reliability and optics of our injection systems. Therefore one new experiment involves the design and construction of a high-current injector module. We are investigating two different approaches. The first uses large diameter, low current density thermionic sources (hot plate or alumino-silicate sources). These sources have been our main line for many years. They produce a current of the order of 1 A per beam. They can produce low emittance beams but they are large, have limited life, and have high power consumption. Size is a particular issue for systems that require many beams (10 to 1000). Consequently we are developing a second approach that uses hundreds of miniature high current density beamlets to form a single beam. Presently, both plasma sources and arc sources are candidates. The injector designs using the multiple beamlet approach are much more compact than the designs using thermionic sources. There are, however, important issues associated with gas loading and its effect on energy spread and voltage holding capability. We are building a new 500 kV ion source test stand at Livermore to address these issues. Kwan, et al. [14] give more details about the injector experiments.
3. A High Current Experiment (HCX). Here the goal is to transport driver scale current (a single beam with an initial current of the order of 1A) through electrostatic and magnetic lattices (10 to 100 lattice periods). The HCX will extend our data base by nearly two orders of magnitude in current. Seidl, et al., [11] give more details. The HCX is currently under construction at Berkeley. The first results are expected in 2001.
4. Technology development. The main cost centers of an induction linac for inertial fusion are multi-beam quadrupole arrays, insulators, ferromagnetic materials for the induction cores, and pulsers. We are developing electrostatic arrays and superconducting and normal magnetic arrays. For the magnetic arrays our goal is an array cost of  $< \$10/\text{k} \cdot \text{m}$  of conductor. We have a contract with Advanced Magnet Laboratory to develop low-cost fabrication techniques. The first superconducting test coils are now being tested at MIT. The insulator cost goal is  $< \$0.01/\text{V}$ . One possibility for achieving this goal is to cast glassy ceramic insulators with imbedded metal rings for grading and for flanges. Advanced Ceramics has delivered our first test insulators. They have a diameter of approximately half a meter. Our cost goal for ferromagnetic materials is  $\$5$  to  $\$10/\text{kg}$ .



Commercial materials meeting this cost goal are available for low frequency applications in the power industry. We are attempting to adapt these materials to pulsed applications by annealing and developing appropriate interlaminar insulation. There has been good progress as described by Molvik, et al. [15]. The cost goal for pulsers is  $< \$10^{-5}/W$  and  $< \$20/J$ . Several years ago we initiated some small contracts with industry to examine methods to produce inexpensive pulser components. The results are encouraging but research is needed.

If we are successful in the four areas outlined above we will have a strong scientific and technical basis for the IRE.

#### **4. Summary**

In summary, the U.S. Department of Energy has established a new, larger inertial fusion energy program. The program has a new road map with clear milestones and cost goals leading to a demonstration power plant. We have established a Virtual National Laboratory for Heavy Ion Fusion and a Virtual Laboratory for Technology to integrate the research programs at different institutions. Progress in target design has reduced the beam energy requirements by more than a factor of two in the last several years. There have been important experiments in chamber dynamics and other inertial fusion technologies. The accelerator program has moved from a Concept Exploration phase to a Proof of Principle phase. Two new facilities are under construction, an ion source test stand at LLNL and the HCX at LBNL. Finally, there has been important progress toward design of the Integrated Research Experiment or IRE.

The authors thank all the researchers from the VNL, from other laboratories, and from industry who have contributed to the research outlined in this paper.

This work was supported by the Director, Office of Science, Office of Fusion Energy Sciences, of the U.S. Department of Energy by University of California Lawrence Berkeley National Laboratory under contract No. DE-AC03-76SF00098, University of California Lawrence Livermore National Laboratory under contract No. W-7405-Eng-48 and Princeton Plasma Physics Laboratory under contract No. DE-AC02-76CH-O3073.

#### **5. References**

- [1] "Strategic Plan for the Restructured U.S. Fusion Energy Sciences Program" U.S. Department of Energy Report DOE /ER-0684, August 1996.
- [2] Callahan-Miller, D.A., et al., "Progress in Target Physics and Design for Heavy Ion Fusion" Phys. Plasmas 7 (2000) 2083 and Callahan-Miller, D.A., et al., "Progress in Heavy Ion Fusion Targets" Proceedings of the 13th International Heavy Ion Fusion Symposium. To be published in Nucl. Instr. Meth. and private communication.
- [3] Peterson, P. "HIF Liquid Hydraulics Scaling and Pocket Design" Proceedings of the 13th International Heavy Ion Fusion Symposium. To be published in Nucl. Instr. Meth.
- [4] Morley, N.B., et al., "Experimental Investigation of Free Liquid Metal Jets in Vacuum: Preliminary results for IFE Chamber Wall Protection Applications", Fusion Technology, 34 (1998) 1035 and Konkachbaev, A., et al., "Stability and Contraction of a Rectangular Liquid Metal Jet in Vacuum Environment", to appear in Fusion Engineering and Design, 2000.
- [5] Elwell, L.C., et al., "Dynamics of Obliquely Oscillated Turbulent Free Rectangular Jets", Bulletin of the American Physical Society 44 (8).
- [6] Petzoldt, R.W. "IFE Target Injection and Tracking Experiment", Fusion Technology 34 (1998) 831.

[7] Latkowski, J.F., et al., "Selection of IFE target materials from a safety and environmental perspective" Proceedings of the 13th International Heavy Ion Fusion Symposium. To be published in Nucl. Instr. Meth.

[8] Schultz, K.R., et al., "IFE Target Fabrication and Injection - Achieving "Believability" Proceedings of the 13th International Heavy Ion Fusion Symposium. To be published in Nucl. Instr. Meth.

[9] The proceeding of the symposia on Heavy Ion Inertial Fusion describe much of the accelerator research. See for example:

Proceedings of the 13<sup>th</sup> International Symposium on Heavy Ion Inertial Fusion, Nucl. Instr. Meth. 278 (1998).

Proceedings of the Seventh International Symposium on Heavy Ion Inertial Fusion, Fus. Eng. Des. 32-33 (1996).

Proceedings of the 12<sup>th</sup> International Symposium on Heavy Ion Inertial Fusion, Nucl. Instr. Meth. A415 (1998).

[10] Kwan, J., "Elise Plans and Progress", Fusion Eng. Des. 32-33 (1996) 299-308.

[11] Seidl, P.A., et al., "Experiments at the Virtual National Laboratory for Heavy Ion Fusion", MacLaren, S.A., et al., "Results from the Scaled Final Focus Experiment", and Ponce, D.M., et al., "Diagnostics of Plasma Channel for HIF Transport", Proceedings of the 13th International Heavy Ion Fusion Symposium. To be published in Nucl. Instr. Meth.

[12] Qin, H., et al., "Three Dimensional Nonlinear Perturbative Particles of Collective Interactions in Intense Particle Beams", Phys. Rev. Special Topics on Accelerators and Beams 3, in press (2000).

[13] Friedman, A., et al., "Beam Simulations for IRE and Driver-status and Strategy", Proceedings of the 13th International Heavy Ion Fusion Symposium. To be published in the Nucl. Instr. Meth.

[14] Kwan, J., et al., "Ion Sources and Injectors for HIF Induction Linacs", Proceedings of the 13th International Heavy Ion Fusion Symposium. To be published in Nucl. Instr. Meth.

[15] Molvik, A., et al., "Induction Accelerator Efficiency at 5 Hz", Proceedings of the 13th International Heavy Ion Fusion Symposium. To be published in Nucl. Instr. Meth.

## **DISCLAIMER**

This document was prepared as an account of work sponsored by the United States Government. While this document is believed to contain correct information, neither the United States Government nor any agency thereof, nor The Regents of the University of California, nor any of their employees, makes any warranty, express or implied, or assumes any legal responsibility for the accuracy, completeness, or usefulness of any information, apparatus, product, or process disclosed, or represents that its use would not infringe privately owned rights. Reference herein to any specific commercial product, process, or service by its trade name, trademark, manufacturer, or otherwise, does not necessarily constitute or imply its endorsement, recommendation, or favoring by the United States Government or any agency thereof, or The Regents of the University of California. The views and opinions of authors expressed herein do not necessarily state or reflect those of the United States Government or any agency thereof, or The Regents of the University of California.