

# Hydraulic and Thermal Analysis of ITER Standard NB Blanket Module

Weishan Kang, Zhang Fu, Jihong Wu and Zengyu Xu

Southwestern Institute of Physics, P.O. BOX 432, Chengdu, 610064, P.R. CHINA

e-mail contact of main author: kangweishan@swip.ac.cn

**Abstract:** Based on the fabrication methods of forging, drilling and welding, the cooling channels in ITER shield block are drilled radial holes with flow drives. In the old design of FDR2001, the pressure drop in the poloidal hole was very high and it was difficult to achieve uniform flow distribution in the radial holes. In recent years, great improvements in the blanket design were made by ITER international team. Hydraulic and thermal studies on ITER shield blanket module was also carried out by SWIP to assess the hydraulic performance and cooling efficiency, and the flow drives was optimized to achieve “uniform” flow distribution. When some improvements and optimizations were done, the current blanket design was confirmed to satisfy the design requirements according to the results from the analyses.

**Keywords:** ITER, Blanket Module, Hydraulic, Thermal

## 1. Introduction

ITER blanket design has progressed significantly since 2001 [1], which resulted in a reduction in cost and an increase in performance with respect to FDR 2001. One of the most important improvements is the new coolant flow configuration in the shield block (SB). In the current design [2], the cooling circuit in the SB is a matrix of radial holes which are arranged in eight poloidal rows. The rows are fed in parallel by front headers and back drilled collectors, and merge in four couples through the front header. These four couples of rows are linked in series by transverse holes. A special shape of flow driver is mounted inside the radial hole, and coolant flows through clearance between the driver and drilled radial hole, which can not only achieve a high coolant velocity, but also reduce pressure drop (*see FIG.1*). Since its depth and size depend on the back surface of the module, two types of drivers were adopted in the design.

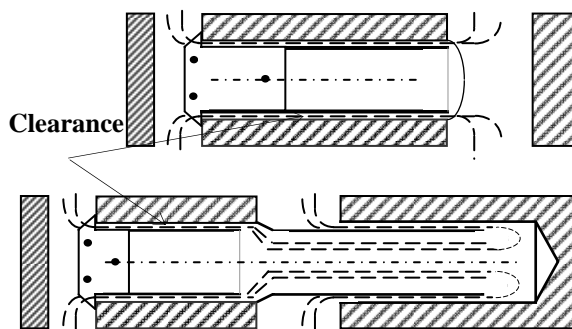

FIG.1. Two types of flow driver in the radial hole; up, single flow (Type 1); down, single plus coaxial flow (Type 2)

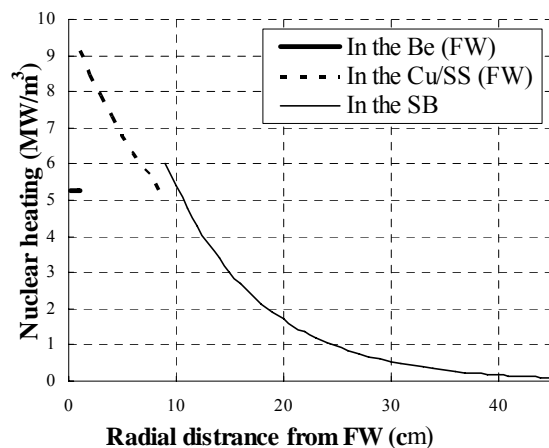

FIG.2. Nuclear heating in the blanket

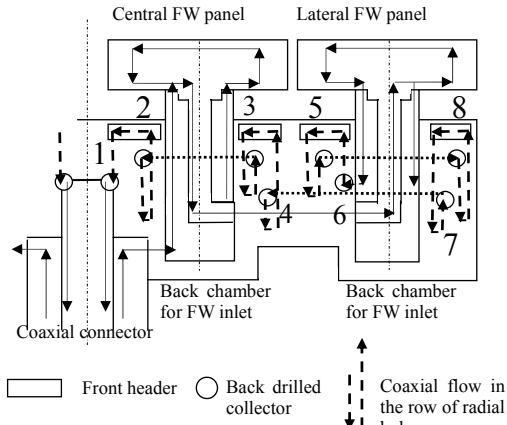

FIG.3. Flow scheme through a half outboard blanket module cut horizontally

The heat flux on the surface of first wall (FW) is  $0.5\text{MW/m}^2$ , and nuclear heating in the FW and SB is as FIG. 2 shown. The flow scheme in the blanket is shown in FIG. 3. Fed by a coolant loop to reach a blanket module, the coolant splits in two streams and reaches the chambers behind the legs of the two central FW panels. Through the legs it flows in the back part of the panels downwards then up in the FW and again down in the back towards the leg. Through a passage in the SB the coolant reaches the next FW panel on both sides of the module. After that it enters the SB. The coolant sweeps the SB from the two sides to the centre, and in the centre the two streams join and leave the module. Note that the flow in the blanket is completely turbulent.

ITER blanket hydraulic and thermal design requires that: (1) overall pressure drop in the module is less than  $0.5\text{MPa}$ ; (2) a coolant velocity suited to remove the heat; and (3) a “uniform” flow distribution, which will reduce thermal stress. Thereby, firstly, the detailed analysis of the cooling circuit in the SB is necessary. Secondly, clearance of flow driver should be optimized with respect to the overall pressure drop and uniform flow distribution. Finally, one of the main goals in this work is to get the minor-loss coefficients in different radial holes, and such data could be used for other blanket module analyses.

In the current design, because of the complexity of the cooling circuit, numerical simulations of the full module are very expensive. Moreover, individual analysis of radial hole is useful for further quick preliminary design optimization. For the reason above, loss coefficient of each drilled radial hole was estimated from detailed individual analysis with CFD code; secondly, pressure drop, velocity and heat transfer coefficient in each hole was obtained according to the mass flow rate and dimensions of the cooling channels in the SB; finally, based on the hydraulic results, thermal analysis is carried out with FEM code to examine if it's suited for removing heat in the blanket.

## 2. Methods

The detailed analysis of the radial hole includes different type of flow driver, (Type 1 and 2) and their reversal flows, different diameter of radial hole (30mm, 45mm and 60mm), length at the back of the radial hole (5mm, 10mm, 30mm, 45mm and 60mm), clearance size (2mm, 3mm and 4mm) and branch velocity.

For straight channel, the pressure drop due to frictional resistance was estimated using the following correlation:

$$\Delta P = 0.5\rho v^2 \lambda L/d, (1)$$

where  $\Delta P$  is pressure loss,  $\rho$  is coolant density,  $v$  is average flow velocity,  $L$  is channel length,  $d$  is hydraulic diameter of channel, and  $\lambda$  is friction factor, defined by [3]

$$\frac{1}{\sqrt{\lambda}} = -2\lg\left(\frac{2.5226}{\text{Re}\sqrt{\lambda}} + \frac{\varepsilon}{3.7065d}\right); (2)$$

where  $Re$  is Reynolds number,  $\epsilon$  is roughness of cooling channel. Eq. (2) is an implicit equation, and it's very difficult to get the rigorous solution, so numerical method is used.

Loss due to flow disturbance was estimated by numerical simulation. The minor-loss coefficient can be expressed by the following relation:

$$\zeta = \Delta P / (0.5\rho v^2), \quad (3)$$

where  $\zeta$  is minor-loss coefficient.  $\Delta P$  and  $0.5\rho v^2$  can be obtained from numerical results. In order to confirm the quadratic dependence of pressure drop with average flow velocity, several different values of velocity were studied.

For estimation of heat transfer coefficient, we used the following correlation:

$$h = Nu\kappa/d, \quad (4)$$

where  $h$  is heat transfer coefficient,  $Nu$  is Nusselt number, and defined by  $Nu = 0.023Re^{0.8} \cdot Pr^{0.4}$ , here  $\kappa$  is thermal conductivity,  $Pr$  is Prandtl number.

### 3. Results and Discussions of Shield Block

Clearances between the drivers and drilled radial holes in a certain row have the same size. Its value is 2, 3 or 4 mm. because the smaller clearance is, and the higher heat transfer coefficient it will give, it should be selected carefully in order to achieve uniform temperature distribution across the rows.

*FIG. 4* is the scheme of flow circuit in a row (Row 6, see *FIG.3*), where “intersection” means the intersection of radial hole with back drilled collector. Each couple of rows shares similar deployment, so we only study one couple, i.e. Row 5-6. It seems impossible to get the rigours solution from Row 6, and simplifying the problem is necessary. As the first step, pressure drop in back drilled collector was ignored, so the radial holes are described as pipes in parallel. Derived from Eq. (1) and (3), pressure loss for a radial hole with subscript “ $i$ ” is expressed by  $\Delta P_i = 0.5\rho v_i^2(\lambda_i L_i/d_i + \zeta_i)$ , (5)

Coolant flowing in the parallel pipes must satisfy the follow equations:

$$Q_{total} = \sum Q_i, \quad (6)$$

$$\Delta P_1 = \Delta P_2 = \Delta P_i = \dots, \quad (7)$$

where  $Q$  is mass flow rate. Note that  $\lambda_i$  is a function of  $v_i$ . It's impossible to get the rigorous solution from these equations, so a numerical method was employed to determine  $v_i$ ,  $Q_i$  and  $\Delta P_i$ .

Based on the above results, pressure drop in the back collector could be included. Such part of pressure drop includes pressure drop due to intersection of radial hole with back collector and branch velocity. It is found that pressure drop due to change in friction factor in the radial hole attributes little (<3%) to the total pressure drop in the row. In an improved calculation, it's assumed that friction factor in the radial hole was fixed, and the values from above results

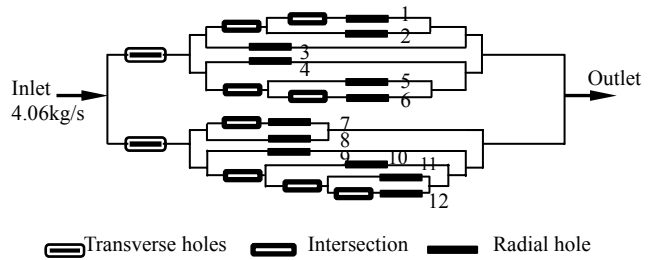

*FIG.4. Scheme of flow circuit of Row 6*

Table I Calculation's results of Row 6, mass flow rate 4.06Kg/s, clearance 4 mm

No.	Hole Type	length (m)	Diam. (m).	Mass flow rate (Kg/s)	Velocity (m/s)	HTCs (W/m <sup>2</sup> K)
1	Type 1	0.184	30e-3	0.39	1.28	11946
2	Type 1	0.184	30e-3	0.38	1.24	11685
3	Type 2	0.21	45e-3	0.36	0.74	7748
4	Type 2	0.21	30e-3	0.21	0.69	7298
5	Type 1	0.184	45e-3	0.60	1.26	11804
6	Type 2	0.21	30e-3	0.23	0.75	7823
7	Type 2	0.21	45e-3	0.43	0.90	8993
8	Type 2	0.21	45e-3	0.40	0.84	8519
9	Type 2	0.21	25e-3	0.16	0.66	7037
10	Type 2	0.184	45e-3	0.34	0.72	7514
11	Type 2	0.21	45e-3	0.35	0.73	7624
12	Type 2	0.21	30e-3	0.22	0.73	7639

were used. The final results are shown in Table I. Row 5 is also studied. Due to usage of the same type of flow driver (Type 2), the velocity distribution is uniform in the Row 5.

Pressure drop and heat transfer coefficient of front head and other straight cooling channels in the SB were obtained using Eq. (1) and (4). Based on the calculation's results, the total pressure drop without considering the loss in the front header in the SB is less than 0.02MPa.

A FEM thermal analysis was carried out. The results indicate that maximum temperature at all places was well within design limits. All deformations were compatible with split cuttings (3mm) and inter-module gaps (20mm).

As indicated in Table I, because different type of flow driver was used and their difference in loss coefficient is large, the flow distribution is not very uniform. An optimization was done in order to reduce the difference in loss coefficient. The clearance in the lower part of the radial hole was adjusted properly(see FIG.5), and the loss coefficient of Type 2 flow driver can be reduced significantly, so the difference between the two types of flow drivers in the loss coefficient diminished. Flow distribution become more uniform and pressure drop decreases. Additionally, since nuclear heating at back end is lower, such optimization can reduce heat remove capability at this part and keep better temperature distribution of the radial hole.

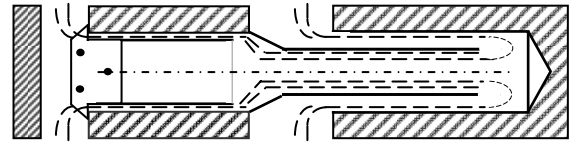

FIG.5. Optimization of Type 2 flow driver

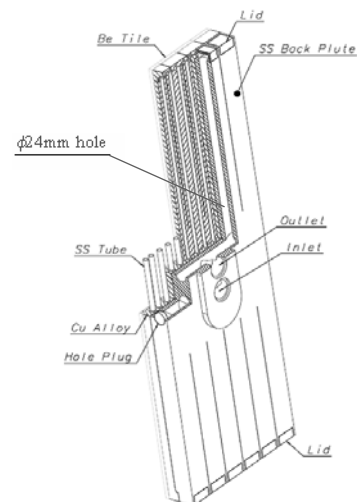

FIG.6. Back view of FW panel

#### 4. Results and Discussions of First Wall

For FW, the cooling circuit is simple (see FIG.6) and can be described as pipes linked in parallel. According to the calculation's results, the total pressure in the FW is less than 0.11 MPa.

Table II Results of thermal analysis in the FW

	Be tile	Cu alloy	SS back plate	SS tube
Max Temperature (°C)	261	225.9	230.2	203.5
Allowable	600	400	400	400
Max Mise Stress (MPa)	406	113	309	285
Allowable	--	303	429	429

Because these parallel pipes have nearly the same dimension and shape, the velocity distribution is fairly uniform. The velocity reaches 4.53 m/s in the SS cooling tubes, and 1.57 m/s in the  $\phi 24$ mm holes. The corresponding heat transfer coefficient is about  $2.9 \times 10^4$  W/m<sup>2</sup>K and  $1.0 \times 10^4$  W/m<sup>2</sup>K, respectively.

A FEM thermal analysis was also carried out, and the results indicate that the maximum temperature and thermal stress in the FW are both bellow the allowable values (see Table II), which confirms the feasibility of current FW design.

## 5. Conclusions

The hydraulic and thermal analysis concludes that:

- a) total pressure drop in the blanket module is less than 0.13MPa;
- b) there is not overheating happening in the blanket;
- c) the flow distribution is uniform, particularly when Type 2 flow driver is optimized.

## Acknowledgement

Thanks to Dr. Ioki and Dr. Elio, Vacuum Vessel and Blanket Division, ITER Garching Joint Work Site, for their help and guidance in the work. Thanks to Dr. Iida, Nuclear Technology Division, ITER Naka Joint Work Site, for providing the heat load data near NB port.

## References

- [1] K. Ioki and V. Chuyanov for the ITER International Team and Participant Teams, Convergence of Design and Fabrication Methods for ITER Vacuum Vessel and In-vessel Components, 20th IAEA Fusion Energy Conference, November 2004.
- [2] ITER Design Descriptions Document Blanket 1.2.1, ITER internal report.
- [3] C. F. Colebrook, Turbulent Flow in Pipes, with Particular Reference to the Transition Region between Smooth and Rough Pipe Laws, J. Inst. Civil Engrs., Vol. 11, February 1939.