

TREATMENT AND RADIOLOGICAL CHARACTERISATION OF CONTAMINATED SOIL AT NPP A1, SLOVAKIA



Martin Listjak, Miroslav Baca, Michaela Svitokova, Alojz Slaninka

VUJE, a.s., Okružna 5, 918 64 Trnava, Slovakia
martin.listjak@vuje.sk

1. Background and Goal of the present work

The first NPP operated in Slovakia was the A1 NPP Jaslovske Bohunice. It was finally shutdown in 1977 after an accident (level 4 according to the INES Scale). Flooding of the underground tanks and some other operational malfunctions are origin of contaminated soil in the site. Dominant RN in NPP A1 site is ^{137}Cs which activity is few order of magnitude higher than other RNs due to long time after final shut down of NPP.

This paper gives an overview of recent activities aimed at treatment of contaminated soil.

2. Origin of the contamination

- incidents during operation of NPP A1 and after its final shut down
 - vicinity of underground tanks in auxiliary buildings
 - cooling towers pond
- temporal storages of loose radwaste:
 - sludge of bioclar from operation of NPP V1 and V2 (obj.839)
 - Arched shed



3. Facilities for monitoring of contaminated soil

Contaminated Soil Sorting System (PTKZ)



- 5 m³ per working shift
- drying and sieving
- 30 kg batches for clearance sorting

Large Capacity Monitoring Post (VMP)



- 10 m³ per working shift
- MDA 10 Bq/kg (^{137}Cs)
- 0,5-2,0 g.cm⁻³
- energy range 0,2-2,0 MeV

Monitor of UNC loader



- 30 s counting time
- MDA: 100 Bq/kg (^{137}Cs)
- no operator during operation
- Colour light signaling

Conclusions and Acknowledgements

- All contaminated soil will be treated by the end of the second stage of D&D project in 2016. By this date all soil should be in big bags and temporarily stored in excavation pit near obj.28 and after VLLW repository commissioning transported there. Soil which does not meet criteria for VLLW repository must be stored in 200 dm³ drums. More than 8.000 big bags were produced from 2013 till 2014
- The author gratefully acknowledges the work of internal and external experts who contributed to the presented results.

4. Manipulation means



5. Management of contaminated soil

Clearance mode

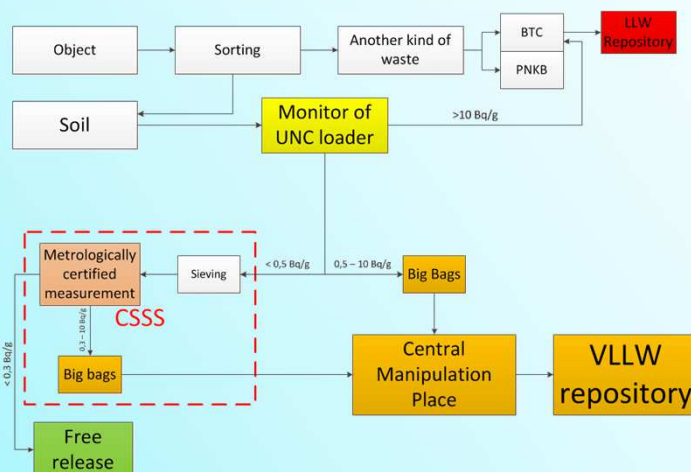

Sorting mode

