

SMOPY a new NDA tool for safeguards of LEU and MOX spent fuel

A. LEBRUN,

French Atomic Energy Commission,
CEA Cadarache 13115 St. Paul Lez Durance

M. MERELLI, J-L. SZABO,

French Atomic Energy Commission,
CEA Saclay 91191 Gif/Yvette Cedex

M. HUVER,

EURISYS MESURES,
Montigny le Bretonneux 78067 St. Quentin en Yvelines Cedex Cedex

R. ARLT, J. ARENAS-CARRASCO,

IAEA International Atomic Energy Agency,
Wagramer Strasse 5, P.O. Box 100 A-1400 Vienna

Abstract

Upon IAEA request, the French Support Program to IAEA Safeguards has developed a new device for the control of the irradiated LEU and MOX fuels. The Safeguards Mox Python (SMOPY) is the achievement of a 4 years R&D program supported by CEA and COGEMA in partnership with EURISYS MESURES.

The SMOPY system is based on the combination of 2 NDA techniques (passive neutron and room temperature gamma spectrometry) and on line interpretation tools (automatic gamma spectrum interpretation, depletion code EVO). Through the measurement managing software, all this contributes to the fully automatic measurement, interpretation and characterization of any kind of spent fuel.

The device is transportable (50 kg, 60 cm) and is composed of four parts :

1. the measurement head with one high efficiency fission chamber and a micro room temperature gamma spectrometric probe,
2. the carrier which holds the measurement head. The carrier bottom fits the racks for accurate positioning and its top fits operator's fuel moving tool,
3. the portable electronic cabinet which includes both neutron and gamma electronic cards,
4. the laptop PC which gets inspectors data, controls the measurement, get measured values, interprets them and immediately provides the inspector with worthwhile information for appropriate on the field decisions.

Main features of SMOPY are:

- discrimination of MOX versus LEU irradiated fuels in any case,
- full characterization of irradiated LEU (burnup, cooling time, Pu amounts ...),
- Partial Defect Test on LEU fuels.

A first version of SMOPY was tested in industrial condition during summer 2000. This tests showed a need of shielding improvement around the gamma detector. A new version has been built and the LEU to MOX distinction feature will be qualified during a new field test.

1 Introduction

The SMOPY¹ (Safeguards Mox Python) device was developed upon IAEA request in the frame of the French Support Program. Basically the SMOPY device is based on the methodology developed for the PYTHON system devoted to irradiated fuels measurements for safety criticality purposes.

Main differences come from the Agency requirements that are summarized in the following paragraph. The paper describes the system itself, then main features are explained.

¹ The SMOPY device was patented under French reference n° 99-00575 (1999).

2 IAEA requirements

Upon task FRA 0115, the agency requested a system able to :

- recognize a MOX fuel from a LEU fuel after only one irradiation cycle and during reactor outage,
- characterize LEU irradiated fuels,
- perform a Partial Defect Test on LEU fuels.

From a technological point of view, other specifications come from the specific use of the device which is devoted to field safeguards measurements.

The system has to be :

- as small as possible, for easy transportation,
- as simple and safe as possible for good acceptance by NPP operators,
- based on robust technology for routine operation,
- combined to an automatic interpretation software, for use by inspectors non expert in spent fuel NDA,
- commercially available and maintainable.

3 Smopy system description

As shown in figures 1, 2 and 3, the SMOPY device is an integrated system which is composed of the following items.

1. The cylindrical measurement head (30 Kg, Φ 16 cm, L 60 cm) with one high efficiency fission chamber² and a micro room temperature gamma spectrometric probe³. The gamma detector is protected by a tungsten shielding with remote control that automatically controls the count rate⁴.
2. The carrier which holds the measurement head. The carrier bottom fits the racks for accurate positioning and its top fits operator's fuel moving tool. This low cost part is intended not to leave the power plant. As a result only the weakly contaminated measurement head will be shipped.
3. The portable electronic cabinet which includes both neutron and gamma electronic cards. Gamma electronic is the Agency standard GBS MMCA 166 inserted into a standard portable cabinet.
4. The laptop PC which gets inspectors data, controls the measurement, gets measured values, interprets them and immediately provides the inspector with worthwhile information for appropriate field decisions. The PC communicates with electronics via two serial lines.



Figure 1. SMOPY device under water during measurement

² Fission chamber reference : PHOTONIS CFUL01

³ Gamma probe reference : RITEC SDP/310/Z 5, 20 or 60 mm³

⁴ The remote gamma collimator was patented under French reference n° 99-15469 (1999).

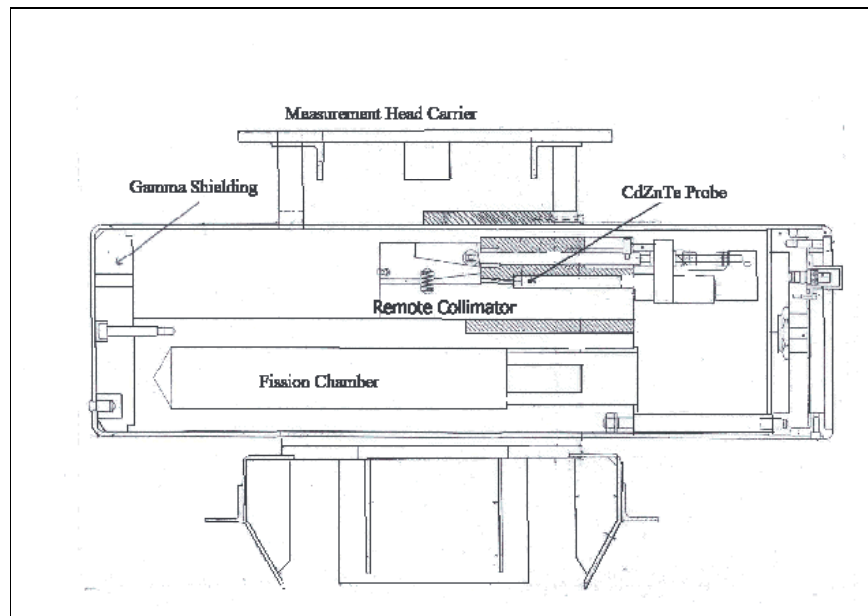

Figure 2. Schematic view of the SMOPY device

4 Features and performances

4.1 Neutron calibration mode

The SMOPY device manages the calibration procedure which requires to perform one single measurement using a known item. The calibration constant for a given fuel geometry links count rate and neutron emission (i.e. the neutron detector yield) is stored into the initialization file and might be used for other similar measurement campaigns. In addition, this yield can be controlled using neutron transport calculation (e. g. MCNP).

4.2 MOX mode to differentiate MOX from LEU irradiated fuels

This feature is the basis of the SMOPY development. It is implemented on IAEA request to face loss of continuity of knowledge during MOX refueling and to be able to recover as soon as possible (namely during the next reactor outage). In such a case, the point is to be able to distinguish one cycle MOX fuel from any irradiated LEU fuel.

In many cases, a simple measurement of the neutron emission by means of passive counting is sufficient. An irradiated assembly with neutron emission lower than 10^8 n/s/t_{HM} cannot be an irradiated MOX assembly because a MOX assembly delivers a neutron emission of $2.28 \cdot 10^8$ n/s/t_{HM} for a burnup of only 5000 MWd/t_{HM}.

Inversely, an irradiated assembly can only be a MOX fuel if its neutron emission exceeds $5 \cdot 10^9$ n/s/t_{HM}. This emission level is attained once the MOX assembly has been through two cycles and this value is never attained by a UOX assembly.

To sum up, the SMOPY device use passive neutron counting alone in both the following cases:

- If the neutron emission is less than 10^8 n/s/t_{HM}, there is no doubt that the assembly is UOX ;
- If the neutron emission is greater $5 \cdot 10^9$ n/s/t_{HM}, there is no doubt that the assembly is MOX.

For neutron emission values between 10^8 and $5 \cdot 10^9$, one cannot be certain whether the assembly is a MOX assembly after one cycle of irradiation or a UOX assembly after at least three cycles. In this case of uncertainty a *reductio ad absurdum* method is implemented in the SMOPY device. This method conclude the inconsistency of the initial hypothesis if the assayed fuel is not a MOX.

The initial hypothesis is that the assembly examined and presented by the operator as a MOX assembly is in fact a UOX assembly. The measurement systems give neutron emission as well as the $^{134}\text{Cs}/^{137}\text{Cs}$ ratio from gamma spectrometry. Feasibility of the gamma measurement after short cooling time was gained during a field test performed together with the AIEA teams in 1998 [2].

To answer the question « What would be the burn-up of an UOX fuel with the measured neutron emission ? » an iterative evolution calculation is performed with regard to a UOX assembly with low initial enrichment (conservative case). Convergence is obtained on the neutron emission from the passive neutron measurement.

The burnup indicator ($^{134}\text{Cs}/^{137}\text{Cs}$ ratio) is extracted from the converged calculation. Simple comparison of the neutron emission ratio on this indicator obtained through calculation on the one hand and measurement on the other hand shows the inconsistency of the initial hypothesis. The following figure illustrates this algorithm.

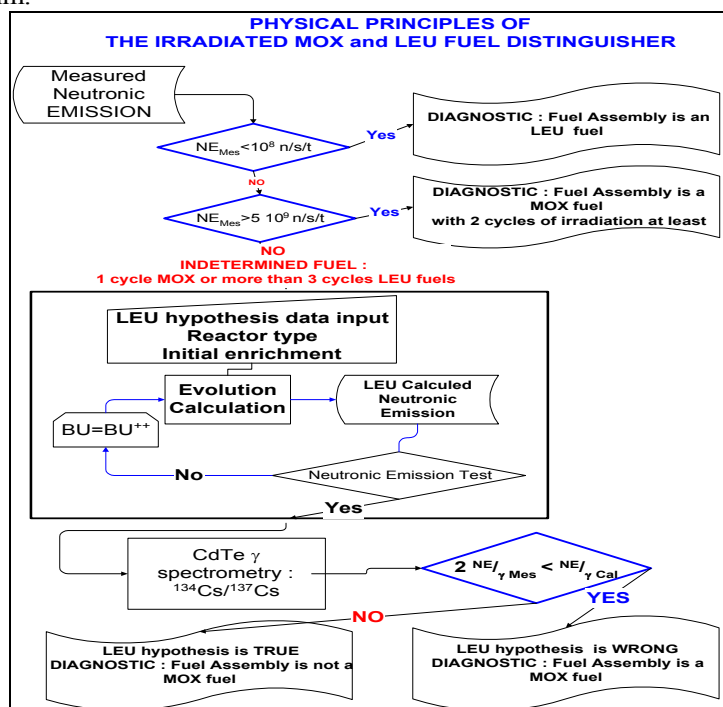

Figure 3. Principle underlying the method for differentiating MOX and UOX assemblies

The MOX to UOX distinguishing capability of the SMOPY device is available whatever the burnup for cooling time from several weeks to several years.

The SMOPY software automatically manages data for up to 15 LWR fuel types.

4.3 LEU mode : Accurate measurement of Burnup of the LEU fuels

SMOPY is able to measure neutron yields and has an on line depletion capability. So the PYTHON methodology for burnup measurement based on neutron measurement is implemented in SMOPY for LEU fuels. This methodology is described in details in reference [3].

This methodology is as follows :

1. using operator data, on line parametric calculations establish the correlation of neutron emission as a function of burnup ($NE=f(BU)$),
2. using neutron detector yield, the neutron count rate is interpreted as a measured neutron emission,
3. multiplication effects are corrected using an iterative process which reaches convergence into the actual burnup within 5% accuracy for PWR fuels.

Figure 4 displays this methodology.

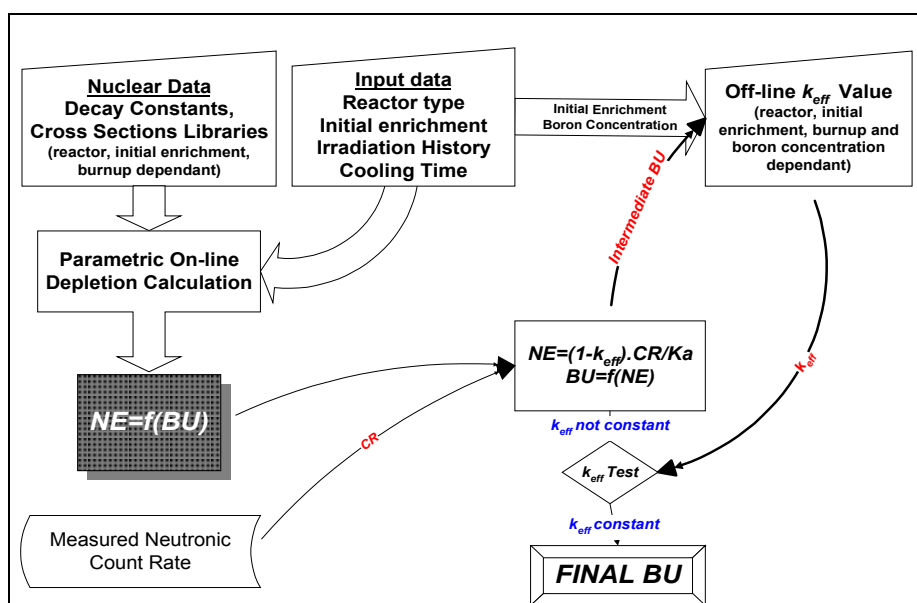

Figure 4. Chart for the use of the calculated correlation curve with correction of the multiplication effects

4.4 PDT mode. Partial Defect Test on LEU fuels

This feature is implemented on IAEA additional request in order to solve the problem of fuel integrity control before loading in long term storage after several cooling years.

Removal of external pins is visible without any measurement. So, SMOPY is supposed to detect removal of internal pins. Gamma emissions are strongly attenuated by uranium pins, so practically, any spectrometric information originates the peripheral zone of the fuels. As a consequence, removal of internal pins does not change the burnup value given by gamma spectrometric assay.

Contrary to gamma probes, neutron detectors assay the whole fuel section. Detector yield contrast is very low and peripheral pins are assayed in the same way as internal pins are. As a result, removal of internal pins that are considered for the Partial Defect Test has a direct influence on neutron count rate.

The Partial Defect Test (PDT) capability implemented in SMOPY is based on a simultaneous control of neutron and gamma emissions ($^{134}\text{Cs}/^{137}\text{Cs}$)⁵.

The SMOPY PDT general methodology can be summarized as follows :

1. use declared data to perform parametric depletion on line calculations,
2. build the correlation laws $NE=f(BU)$ and $^{134}\text{CS}/^{137}\text{CS}=f(BU)$,
3. perform a gamma spectrometry to get the measured $^{134}\text{CS}/^{137}\text{CS}$ ratio,
4. check the declared irradiation history and burnup using measured and calculated $^{134}\text{CS}/^{137}\text{CS}$ ratio,
5. extract neutron emission from depletion calculation,
6. perform a passive neutron counting,
7. correct the multiplication effects regards to boron concentration and verified burnup,
8. SMOPY PDT consists then in a consistency check between calculated and measured neutron emission.
If actual measured neutron emission does not fit the theoretical neutron emission within calculation and measurement uncertainty, the fuel cannot be declared non defective.

This methodology is fully implemented in the SMOPY software. At the moment, no field test is scheduled to validate this feature but a theoretical study will determine the sensitivity of the method.

⁵ Possibly $^{154}\text{Eu}/^{137}\text{Cs}$ ratio might be assayed for very long cooling time.

5 SMOPY software

The SMOPY software is designed following the rules of simplicity and compliance to the Agency approved tools. Measured data (gamma spectrum and neutron count rate) are stored in the GBS MMCA data format. The main screen of the software is as simple as possible. No specialized skills are required to use the software.

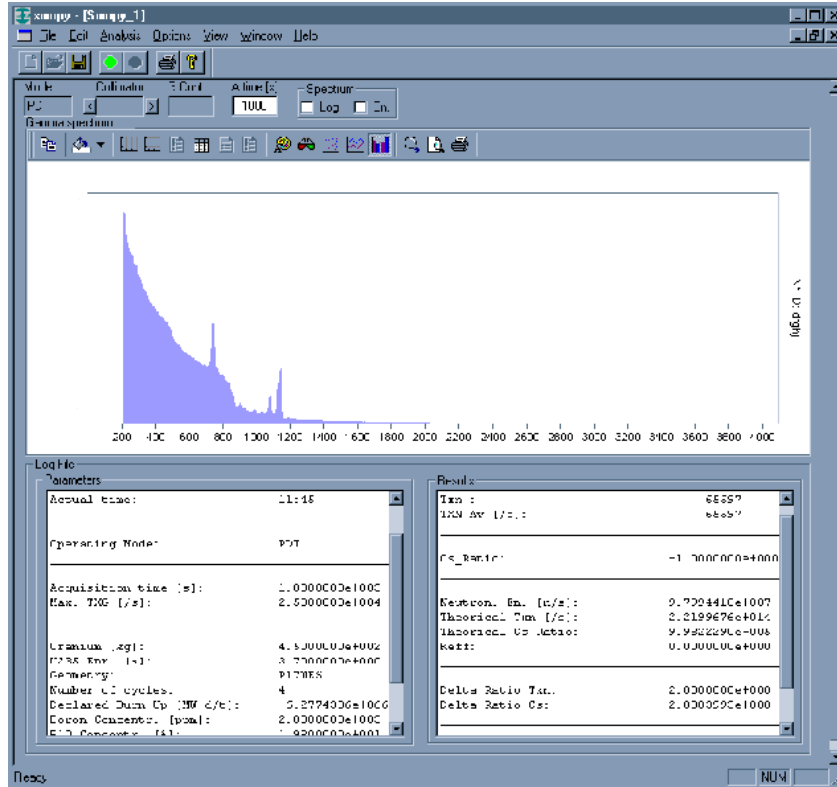

Figure 5. Main operator screen of the SMOPY software.

Inspector's data can be entered through screens like these :

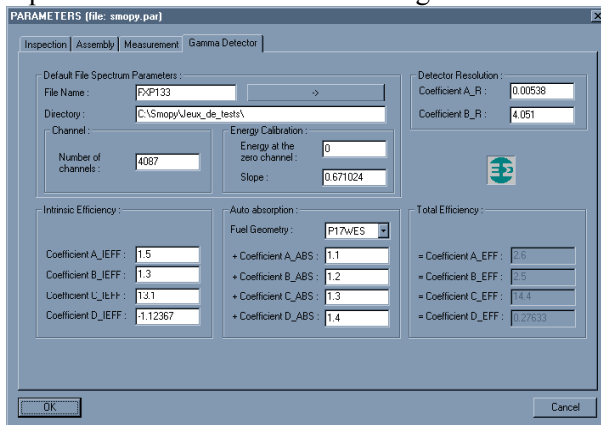

Figure 6. Gamma detector management screen.

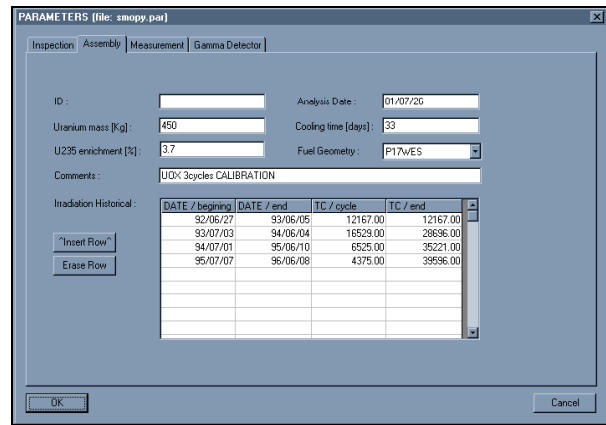

Figure 7. Fuel item data screen.

The SMOPY software provides results through the graphic interface and stores them into files for further analysis. The inspector can observe in the field whether measurement is correct and can also perform deeper analysis and controls at office.

6 Experimental results

Many experiments have been done in hot cells where gamma remote collimator was qualified. Figure 8 displays a gamma spectrum gained with 18 pins of irradiated BWR fuel.

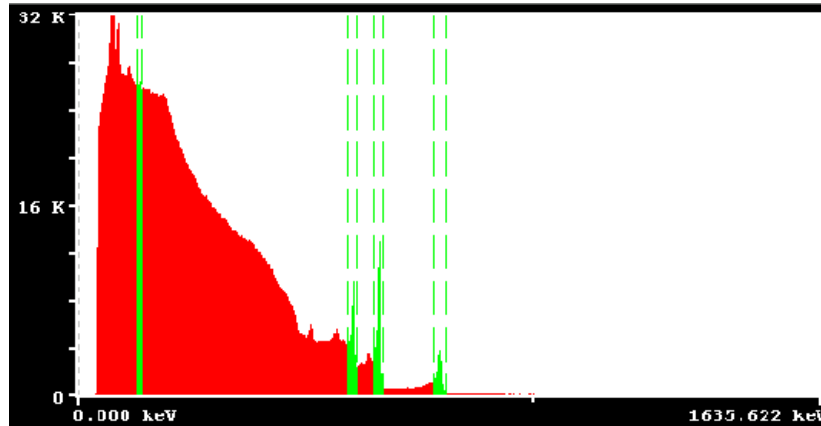

Figure 8. Spent fuel spectrum measured for laboratory qualification on spent fuel pins in hot cell.

A field test was organized in a nuclear power plant during year 2000. The main objective was to validate the MOX mode but also to demonstrate the operability of the device inside a NPP, to validate the software in operation condition and to validate the measurement equipment.

The neutron results gave pretty good results that are displayed in table I. Accuracy of the burnup measurement is within 5% for LEU fuel and as expected MOX neutron emissions are significantly higher than LEU neutron emissions

The actual gamma activity after only 31 cooling days was underestimated and gamma count rate was too high to get accurate results. So, this experiment has shown the need for extra shielding around the detector for very short cooling time. New shielding design is under manufacturing to cope with short cooling time gamma activity but at the same time to keep the device as light as possible for other applications.

Fuel ID	AC1	AC2	AC3	AC5	AC6	Blind test
Fuel type	UOX	UOX	UOX	MOX	MOX	MOX
(Equivalent) Initial Enrichment	3.7	3.7	3.7	3.25	3.25	3.25
Nb Cycles	3	4	3	1	2	1
Irradiation Histories						
08/07/96 03/05/97		8419				
16/08/97 12/06/98	13549	22392	8255			
19/07/98 26/06/99	22671	34211	22725		12600	
15/09/99 01/07/00	37041	37930	33527	11492	25752	11492
Calibration Constant Kn	1.267E-06					
Neutron Emission	4.26E+08	3.98E+08	3.00E+08	2.20E+09	4.50E+09	2.20E+09
Keff (boron =2400ppm)	0.446	0.442	0.459	0.593	0.554	0.593
Analysis Mode	Calibration	UOX Mode	UOX Mode	MOX Mode	MOX Mode	MOX Mode
Txn Foreseen	974	903	702	6847	12780	6847
Txn actually measured	974	885	769	4372	9266	5020
DIAGNOSTICS						
Type (automatic analysis (no spectro available))				UOX	MOX	UOX
Type determined by user with total gamma count rate)				MOX	MOX	MOX
Measured BU UOX mode (Calibration)	37695	34598				1 cycle
Discrepancy $(BU_{mes}-BU_{NPP})/TC_{mes}$		-1%	3%			

Table I. Summary of the results gained during the first field test of the SMOPY device.

The field test demonstrated the full compliance of the device with safety rules in force in NPPs. The software operated like foreseen to manage data acquisition as well as data processing.

7 Conclusions

The IAEA requirements for spent fuel measurements lead to definition and implementation of the SMOPY device. SMOPY is designed to be a multipurpose NDA tool for safeguarding spent fuels. Three attended operating modes are available at the moment (MOX, LEU, PDT).

Partial Defect Test capability is implemented and a theoretical study will determine the sensitivity of the method.

Because the system is self adaptative (remote collimator) and implements on line interpretation tools (depletion online code and automatic gamma interpretation code) unattended monitoring mode might easily be development in the future for unattended Partial Defect Test for instance.

Practical attended operation of the SMOPY device is demonstrated by a successful field test. Underwater operability and safety of the device is demonstrated.

At the moment, the device is being upgraded to face the huge gamma irradiation from MOX fuel after short cooling time. A new field test will be performed to finalize the qualification of the LEU to MOX distinction methodology.

References:

- [1] A. LEBRUN, G. BIGNAN, H. MAKIL, JL SZABO, S. VAUBAILLON, J. ARENAS-CARRASCO, I. CHERRADI, O. HEINONEN , Development of IAEA Safeguards for Irradiated MOX Assemblies Using NDA, 21th ESARDA Symposium, SEVILLA 1999.
- [2] A. LEBRUN, G. BIGNAN, JL SZABO, J. ARENAS-CARRASCO, R. ARLT, A. DUBREUIL, K. ESMAILPUR.KAZEROUNI, Gamma Spectrometric Characterisation of Short Cooling Time Nuclear Spent Fuels Using CdZnTe Detectors, Nuclear Instrument and Methods in Physic Research, , Volume 448, N°3 July 2000.
- [3] A. LEBRUN, G. BIGNAN
Nondestructive Assay of Nuclear Low-Enriched Uranium Spent Fuels for Burnup Credit Application, Nuclear Technology Vol. 135 n°3, September 2001.