

Experimental Facilities for Nuclear Education and Training

Dr. Attila ASZÓDI

Director

Budapest University of Technology and Economics (BME)

Institute of Nuclear Techniques (NTI), Hungary

www.reak.bme.hu

International Conference on Human Resource Development for
Introducing and Expanding Nuclear Power Programmes

14-18 March 2010, Abu Dhabi, United Arab Emirates

Training reactor, Hungary

- Location: Campus of the Budapest University of Technology and Economics (BME)
- Reactor type: pool-type reactor (Hungarian design)
- First criticality: 1971.
- Nominal Power: 100 kW
- Moderator and coolant: light water
- Horizontal and vertical irradiation channels
- Pneumatic dispatch system for the transfer of the samples into the core

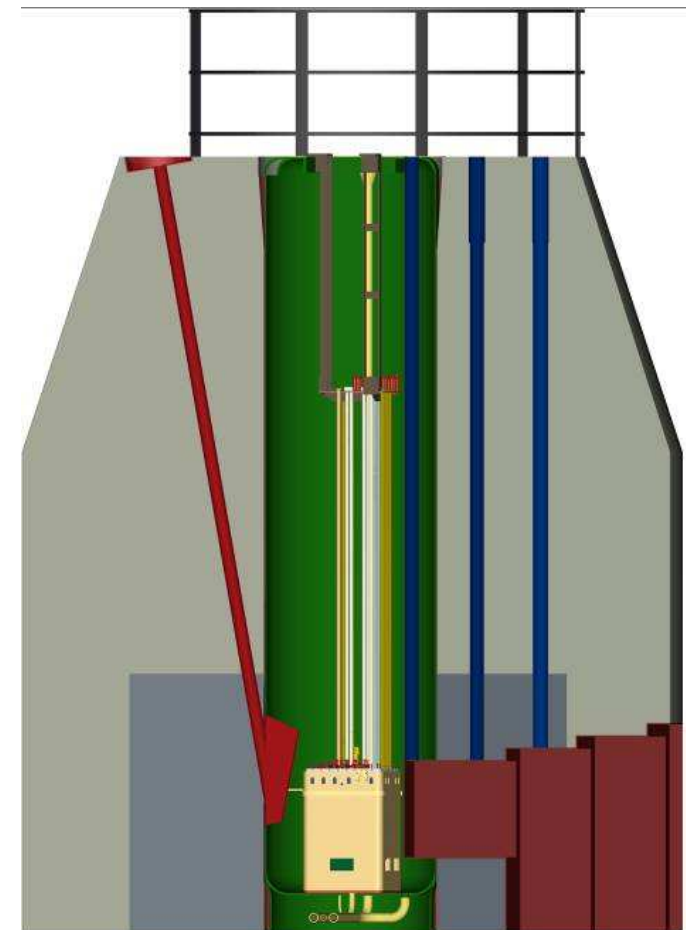

Education at Training Reactor, Hungary

- Main fields of courses:
 - reactor physics,
 - thermal hydraulics,
 - nuclear safety,
 - radiation protection,
 - nuclear measurements and instrumentation,
 - radiochemistry,
 - nuclear power plants
 - nuclear fuel cycle
- Beside the classroom lectures focus on small group experimental work

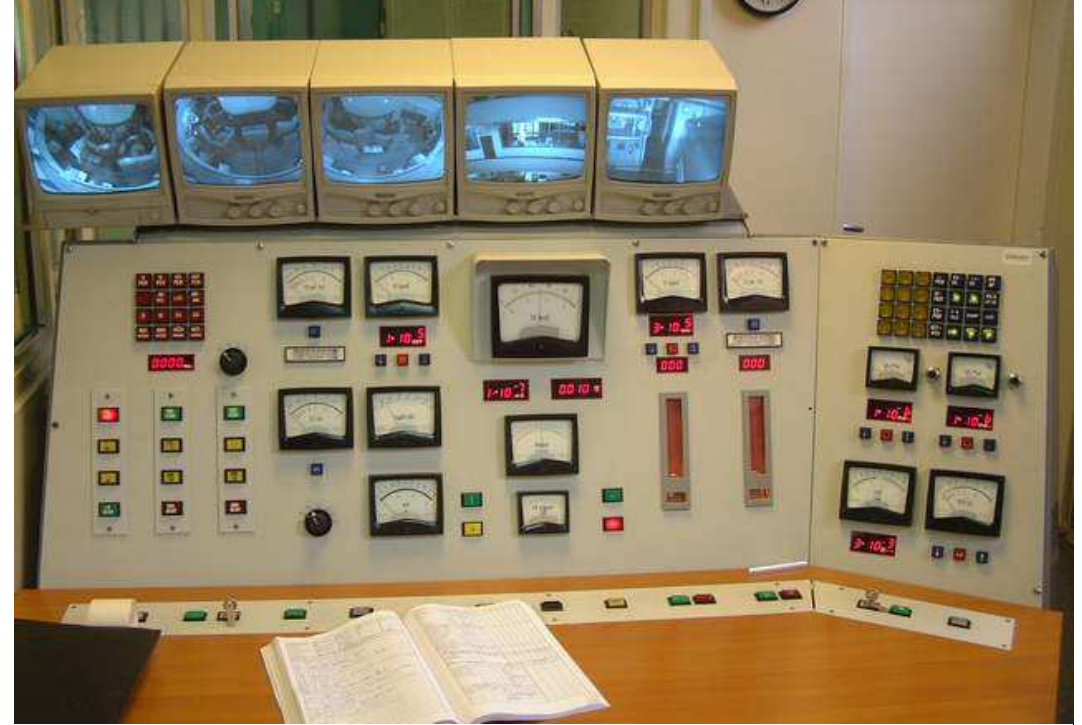

Education at Training Reactor, Hungary

- Levels of courses:
 - BSc, MSc, PhD
 - Post-graduate courses
- Specialties:
 - Engineering-physicist
 - Physics BSc and MSc with nuclear specialization
 - Energy Engineering (power engineering BSc and MSc with nuclear specialization)
 - Very active PhD school
- Measurement exercises for other universities and faculties of BME

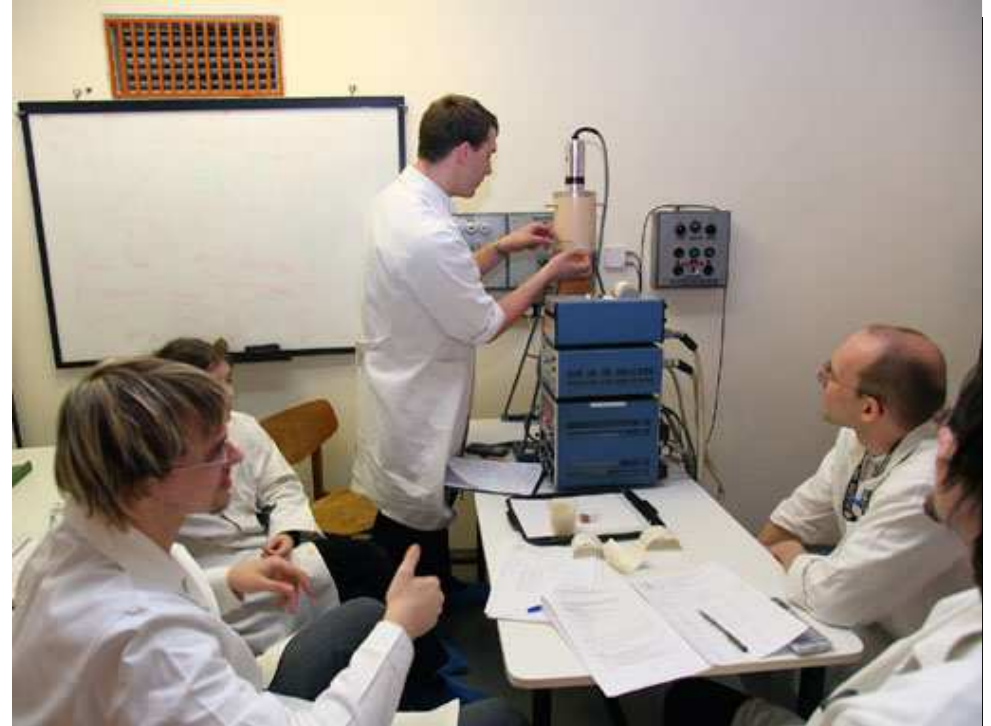

Typical measurement exercises at Training Reactor, Hungary

- Neutron activation analysis
- Determination of thermal neutron flux in the reactor core using neutron activation analysis
- Investigation of delayed neutron parameters, determining of uranium concentration in samples

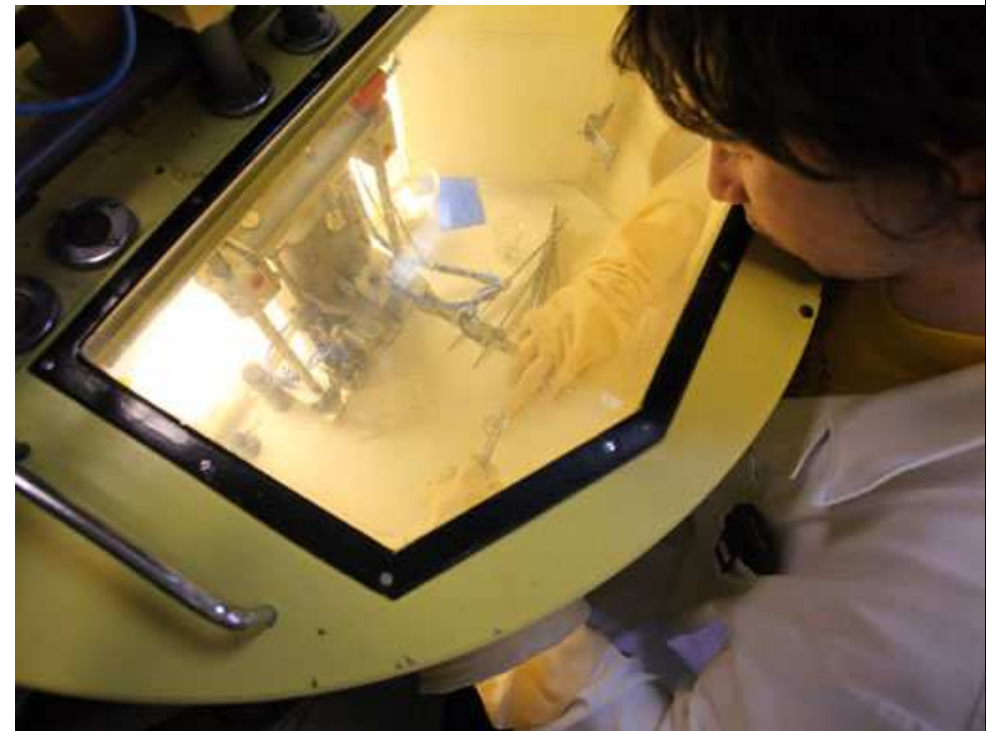
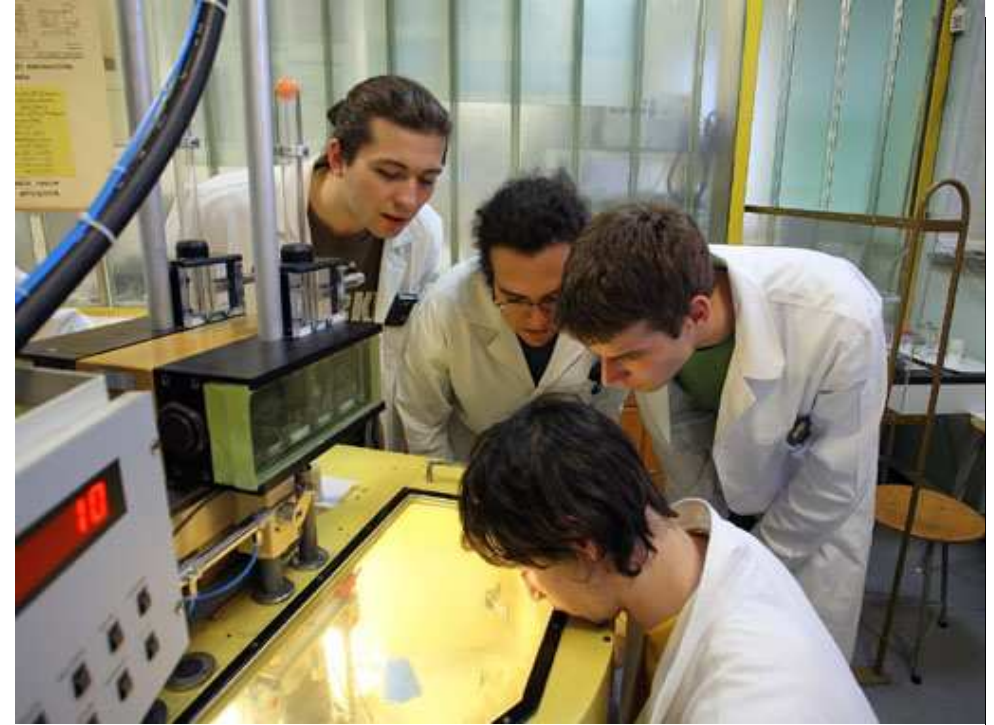

Typical measurement exercises at Training Reactor, Hungary

- Reactor operation exercise
- Measurement of the void coefficient and the control rod reactivity worth
- Measurement of thermal neutron diffusion length in graphite
- Criticality experiment
- Measurement of gamma- and neutron dose rate, radiation protection measurements



Post graduate course in reactor engineering at Training Reactor, Hungary

Continuing Education in Reactor Physics and Reactor Technology

- Applied Mathematics I, II, III
- Reactor Physics I,II,III,IV
- Reactor Technology I,II
- Radiation Protection and Dosimetry
- Environmental Protection
- Nuclear Measuring Techniques I, II
- Thermohydraulics I, II
- Nuclear Power Plants I, II
- Operation of Nuclear Reactors
- Control Technology I,II
- Electrical Devices and Grids
- Energy Systems
- Laboratory Practices I, II, III, IV, V, VI

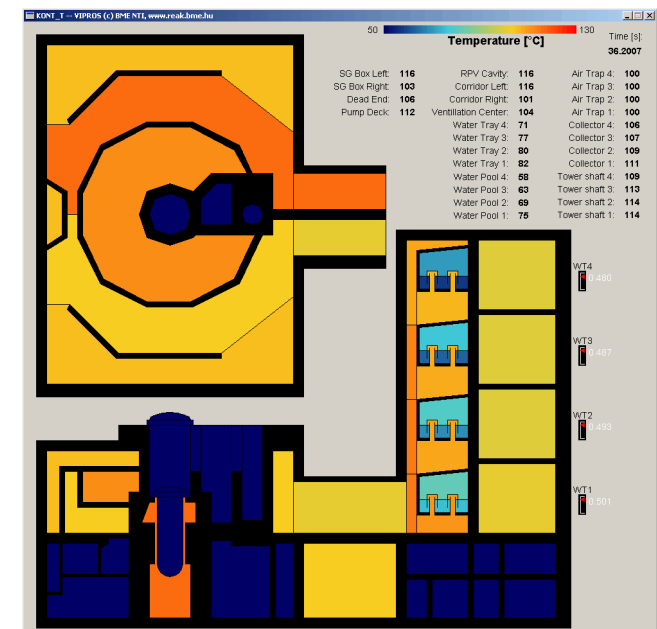

International education at Training Reactor, Hungary

- Slovak Technical University
Bratislava
- Czech Technical University Prague
- Technical University Vienna (Austria)
- The University of Rennes INSA
(France)
- Delft University (The Netherlands)
- École de Mines de Nantes (France)
- International Atomic Energy Agency
(IAEA)
- KTH Stockholm (Sweden)
- International Wigner course on
experimental reactor physics:
cooperation with TU Vienna, TU
Prag, TU Bratislava in the frame of
ENEN
- IAEA - EERRI course



NPP simulators at Training Reactor, Hungary

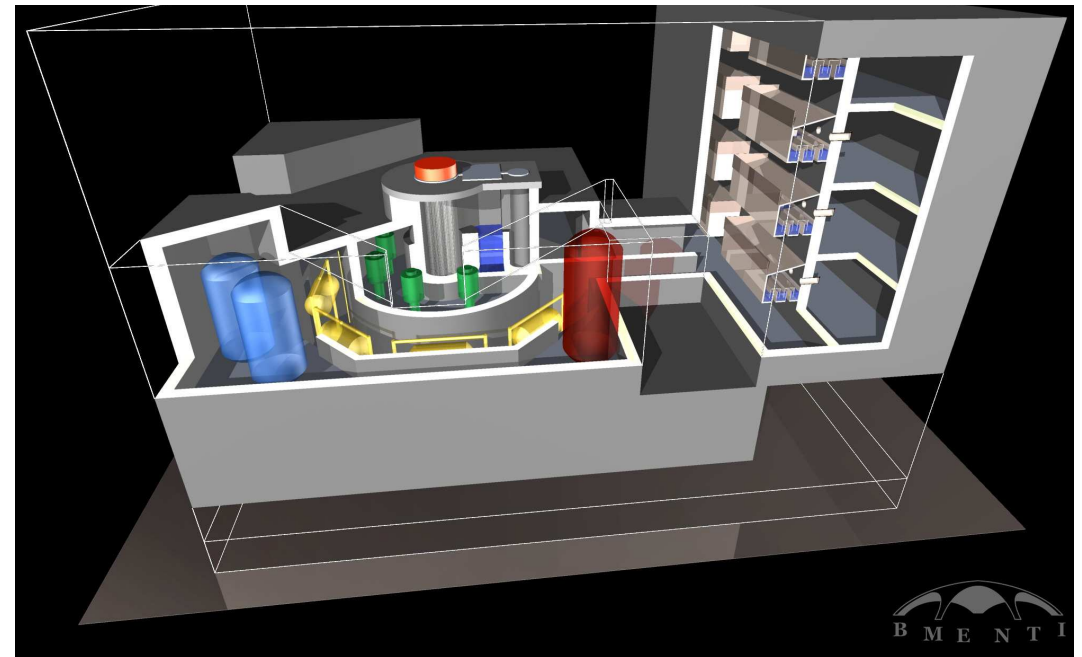
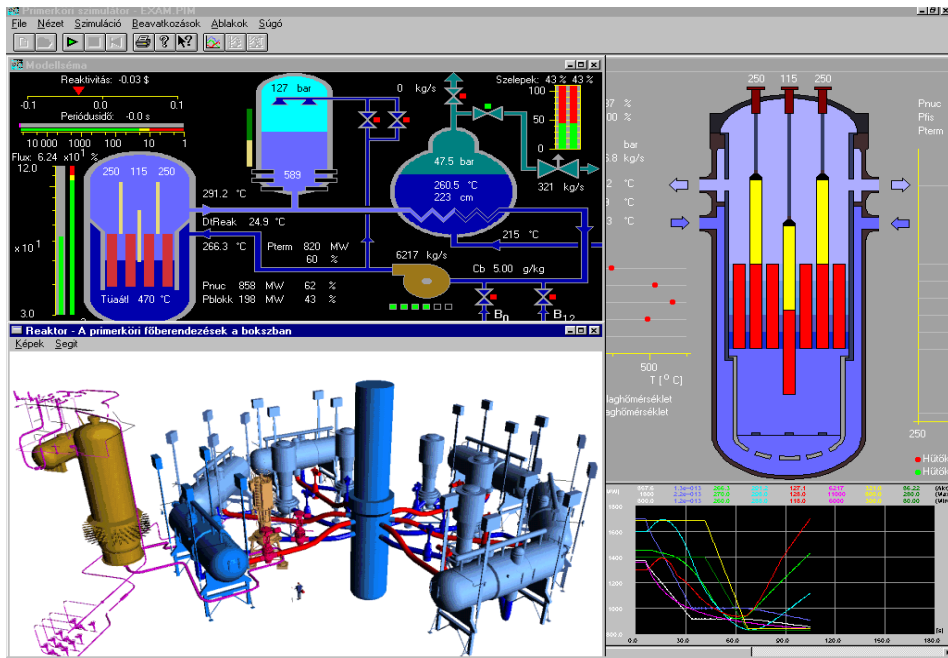

Primary loops

Paks NPP Unit No 3

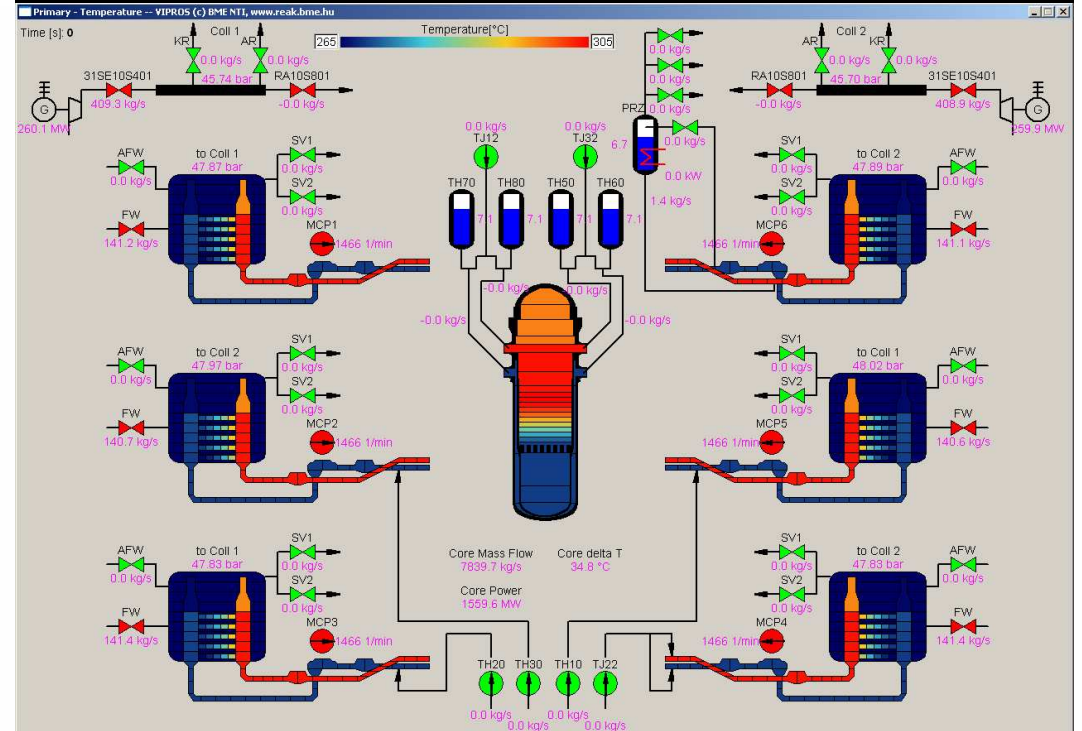
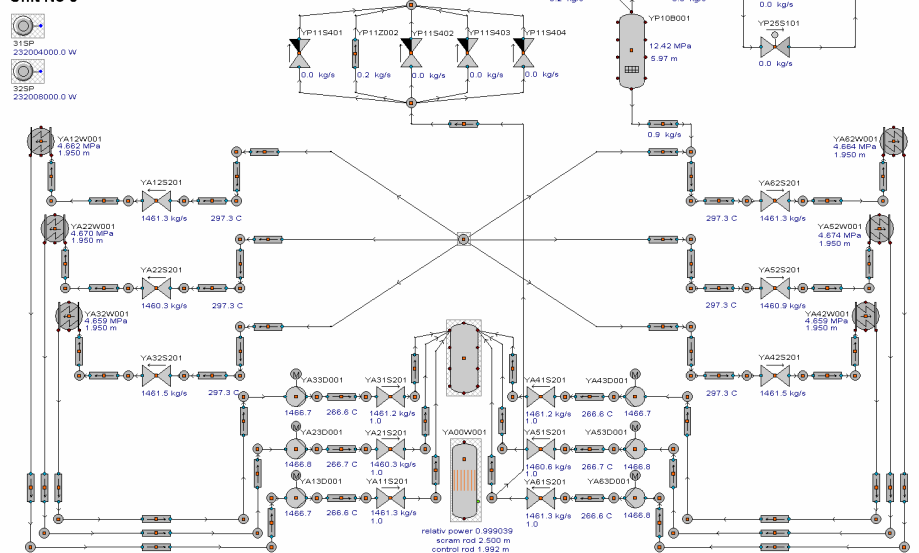

TRATEL – TRAnsparent Thermal-hydraulics TESt Loop

to demonstrate the behaviour of the
coolant in a PWR primary circuit
during normal operation and LOCAs.

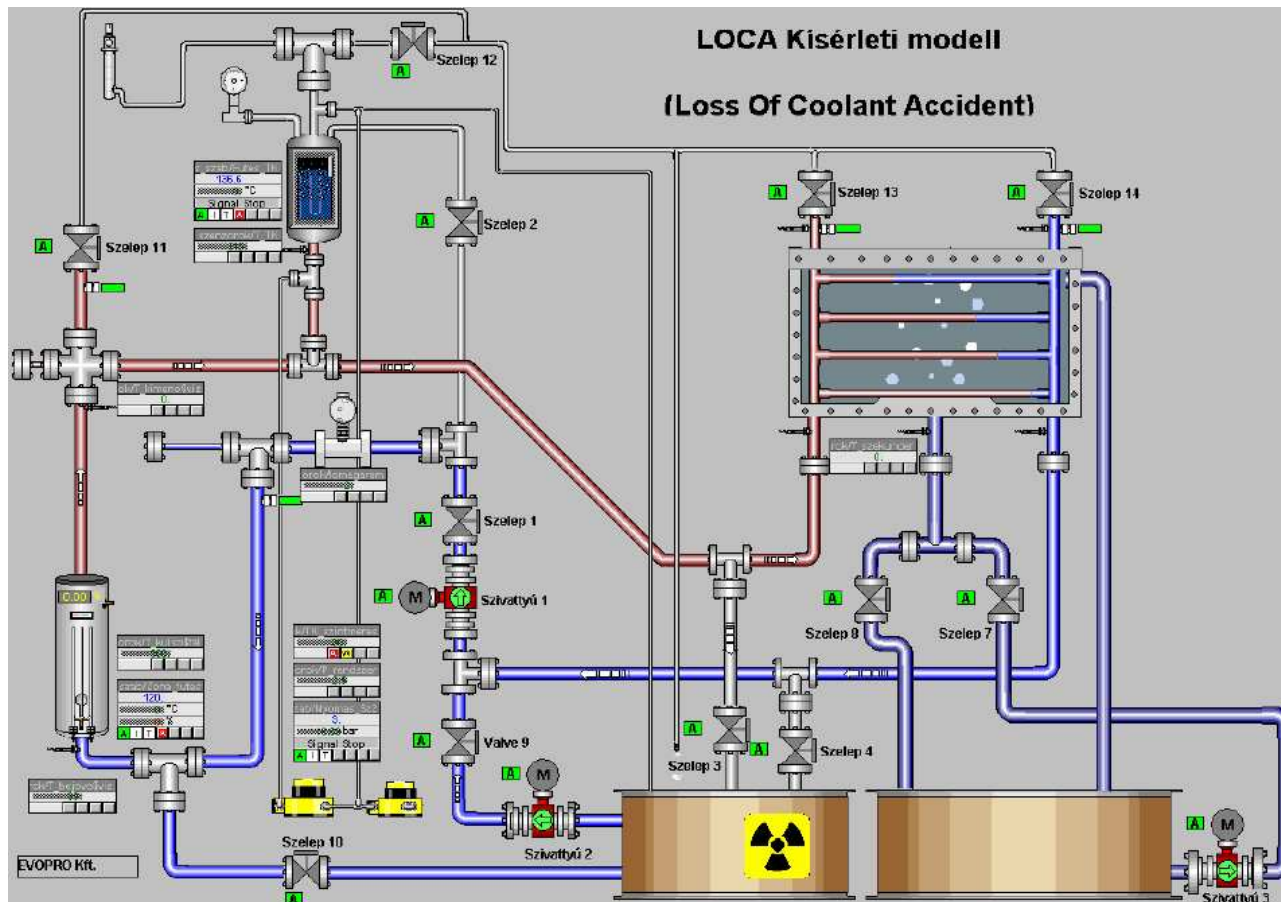

Research at Training Reactor, Hungary

Thermal hydraulics, CFD

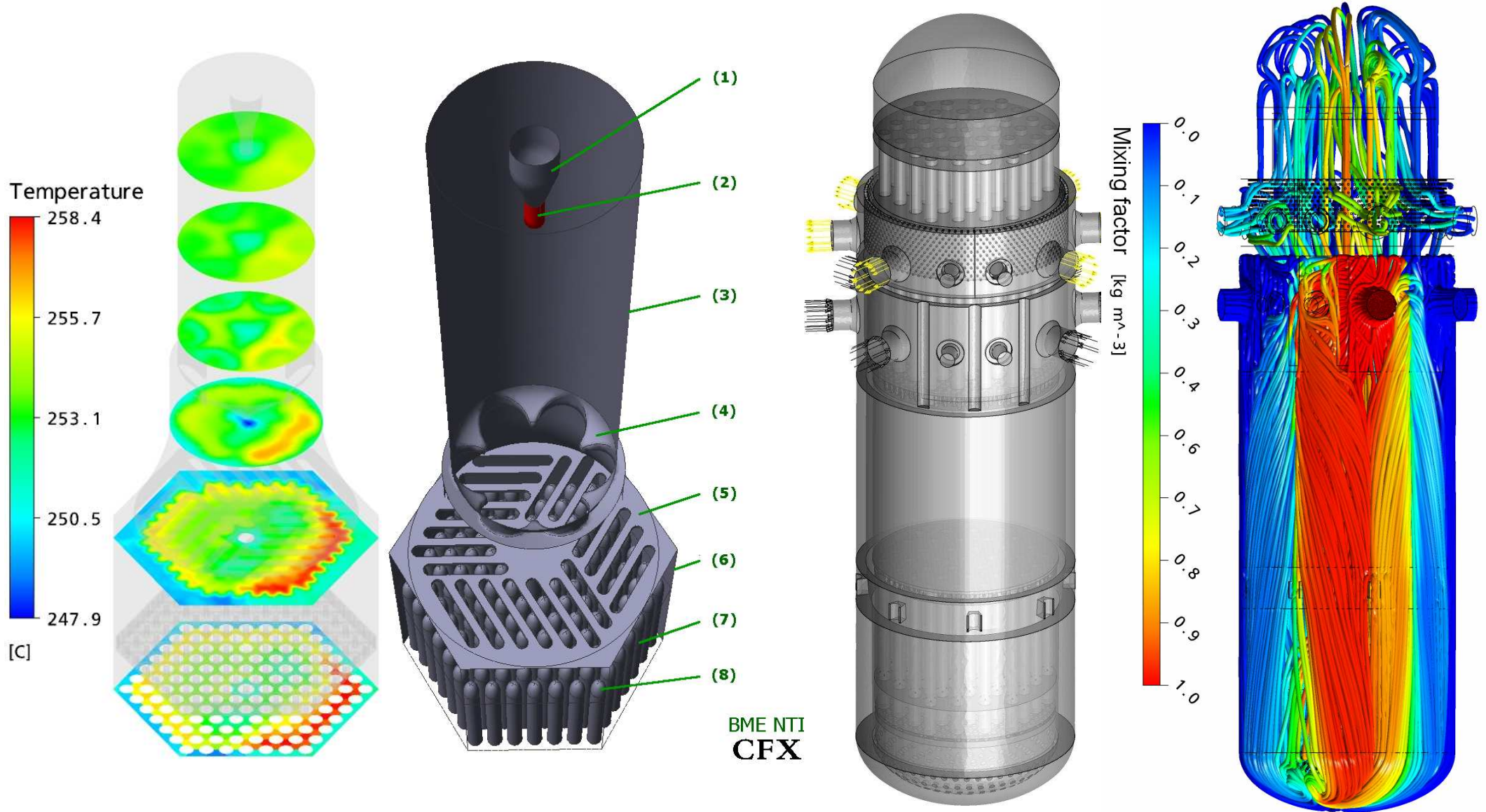

Research at Training Reactor, Hungary

Thermal hydraulics – thermal stratification

Experimental and numerical investigation of thermal stratification and cold plume mixing

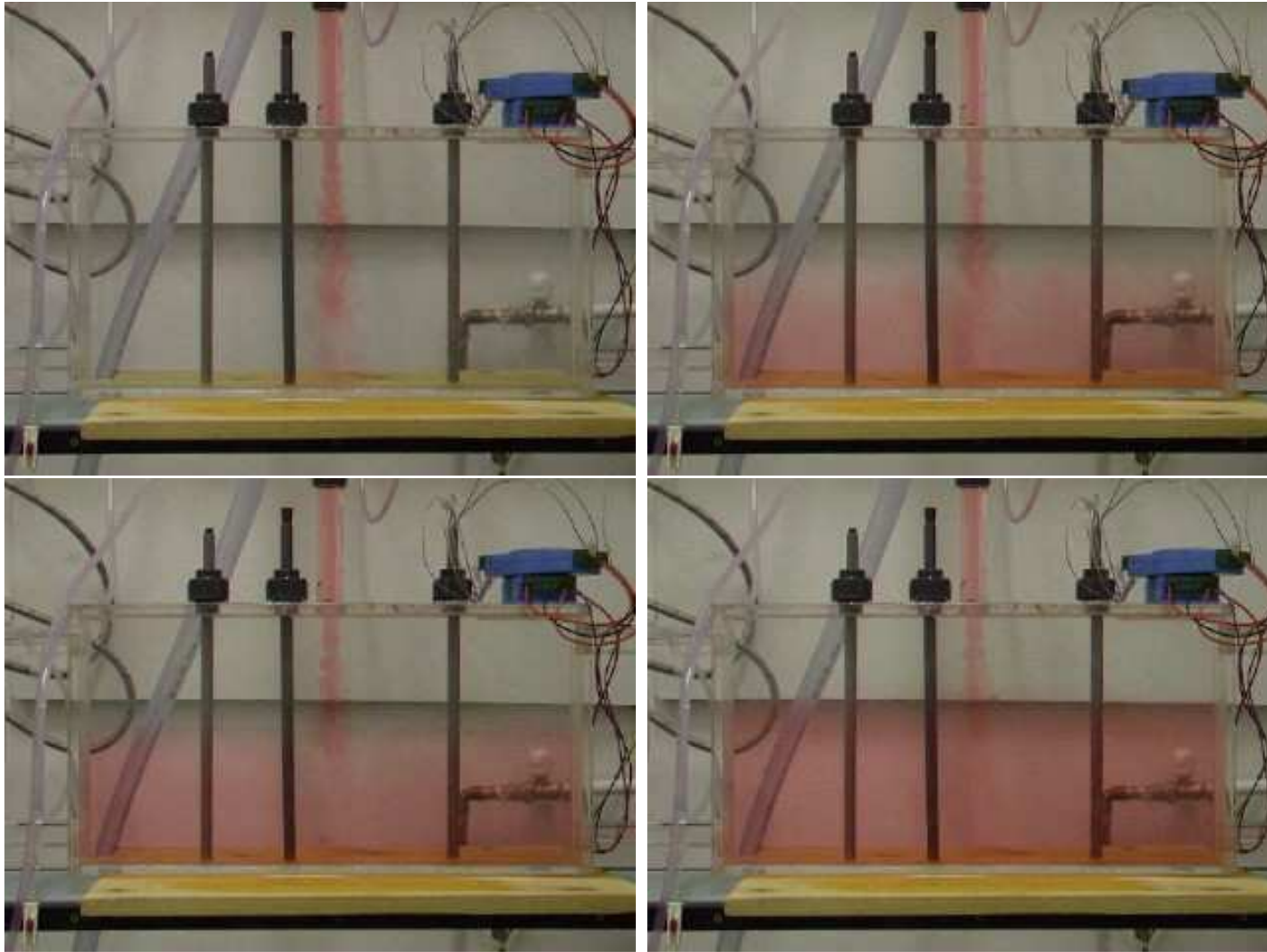
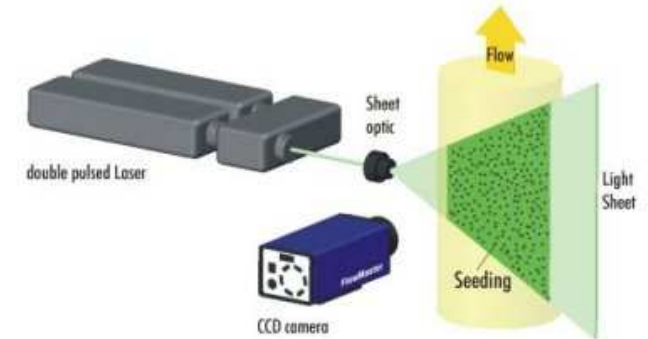
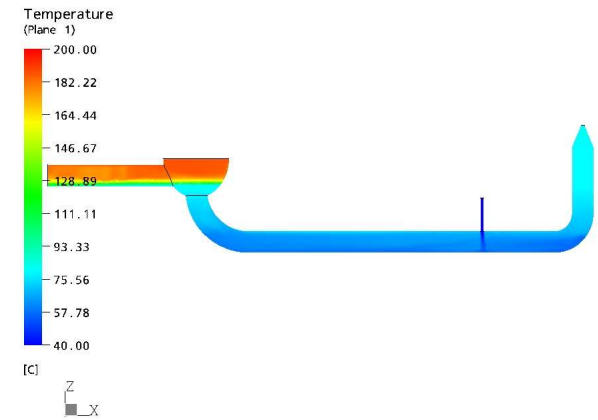

eGMC – USB based GM-counter for education (Training Reactor, Hungary)

- New USB based GM-counters for educational purposes
- 2 versions: with and without own LCD display
- Demonstrations software added



New education: medical physics

- In the frame of Physics MSc course a nuclear medical physics specialization is under preparation
- Goal is to train physicist for
 - hospital's radiotherapy centers
 - hospital's radio diagnostic centers
 - medical instrument and device R&D companies

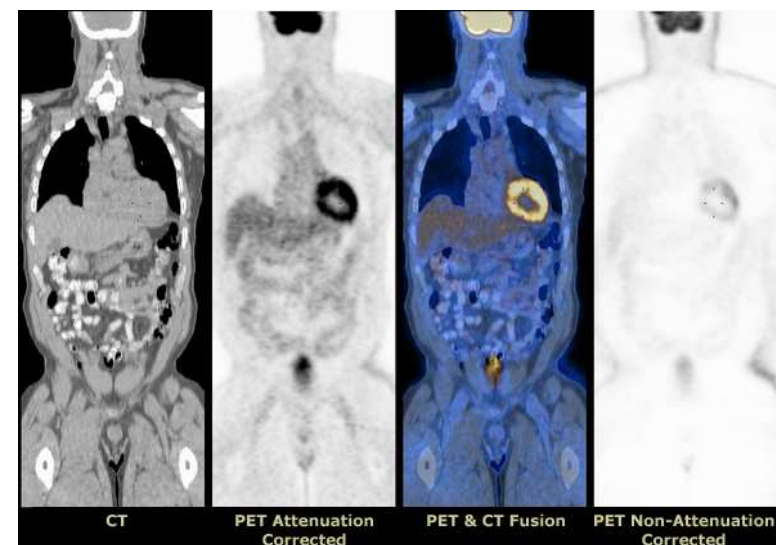
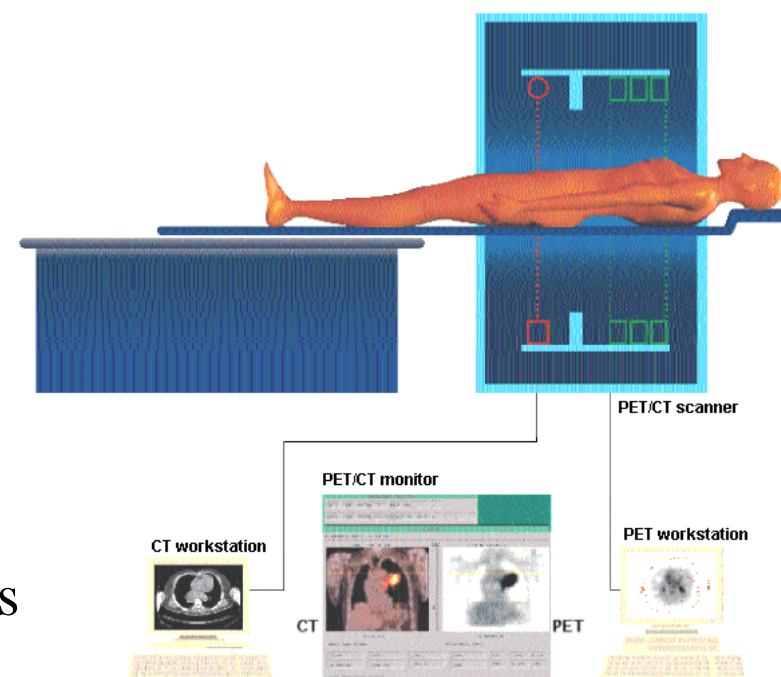

Research at Training Reactor, Hungary

Monte-Carlo Analysis

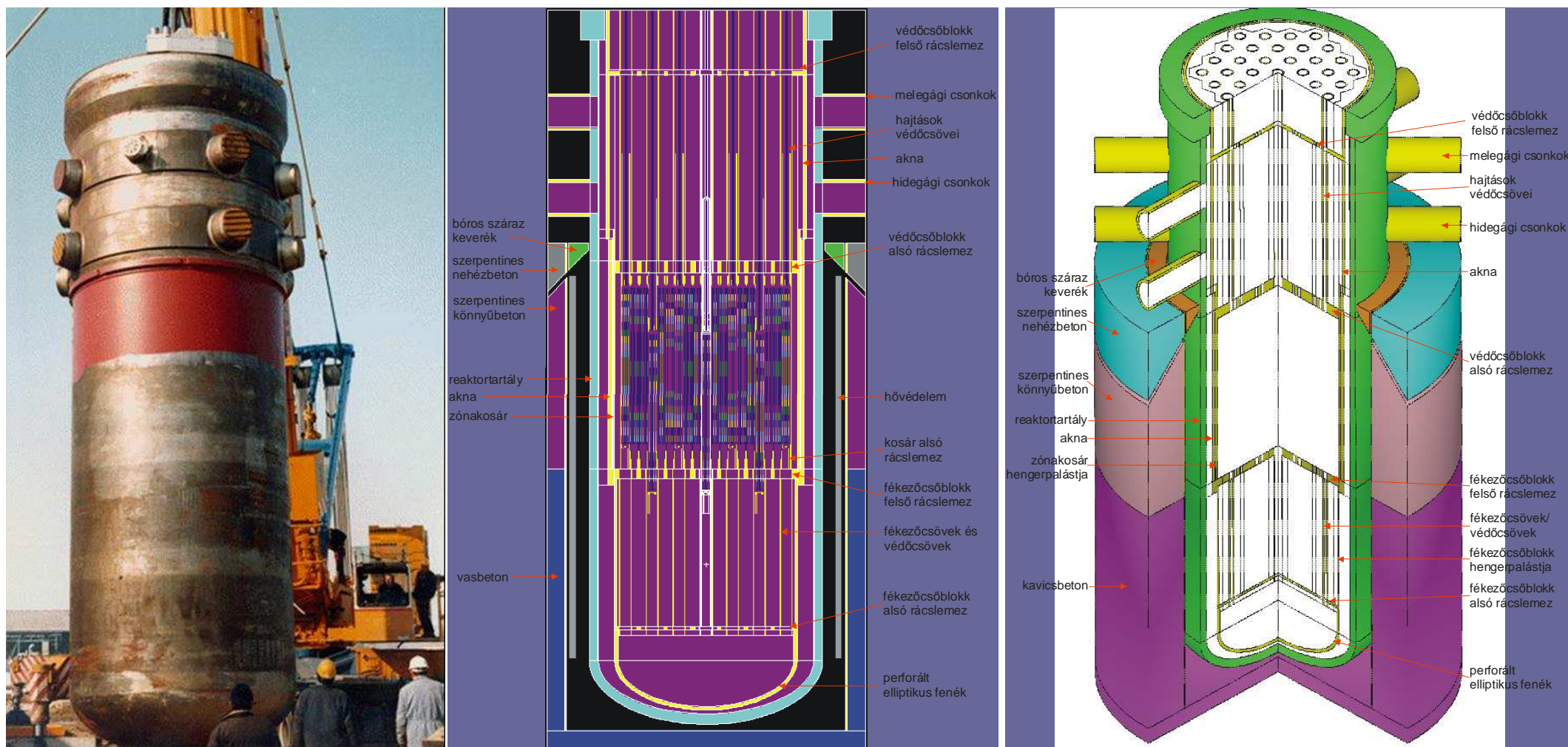

Research at Training Reactor, Hungary

PGET – Passive Gamma Emission Tomography

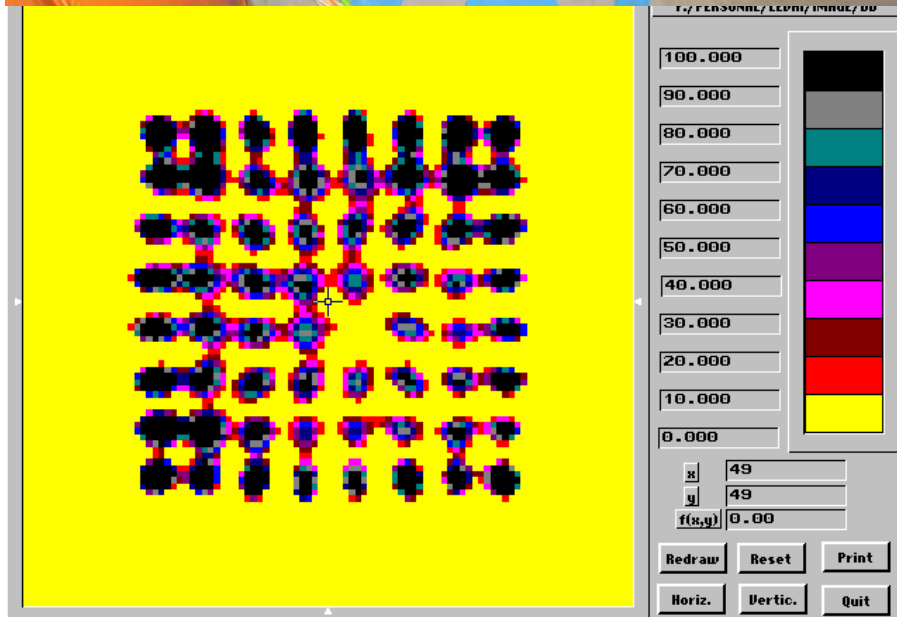
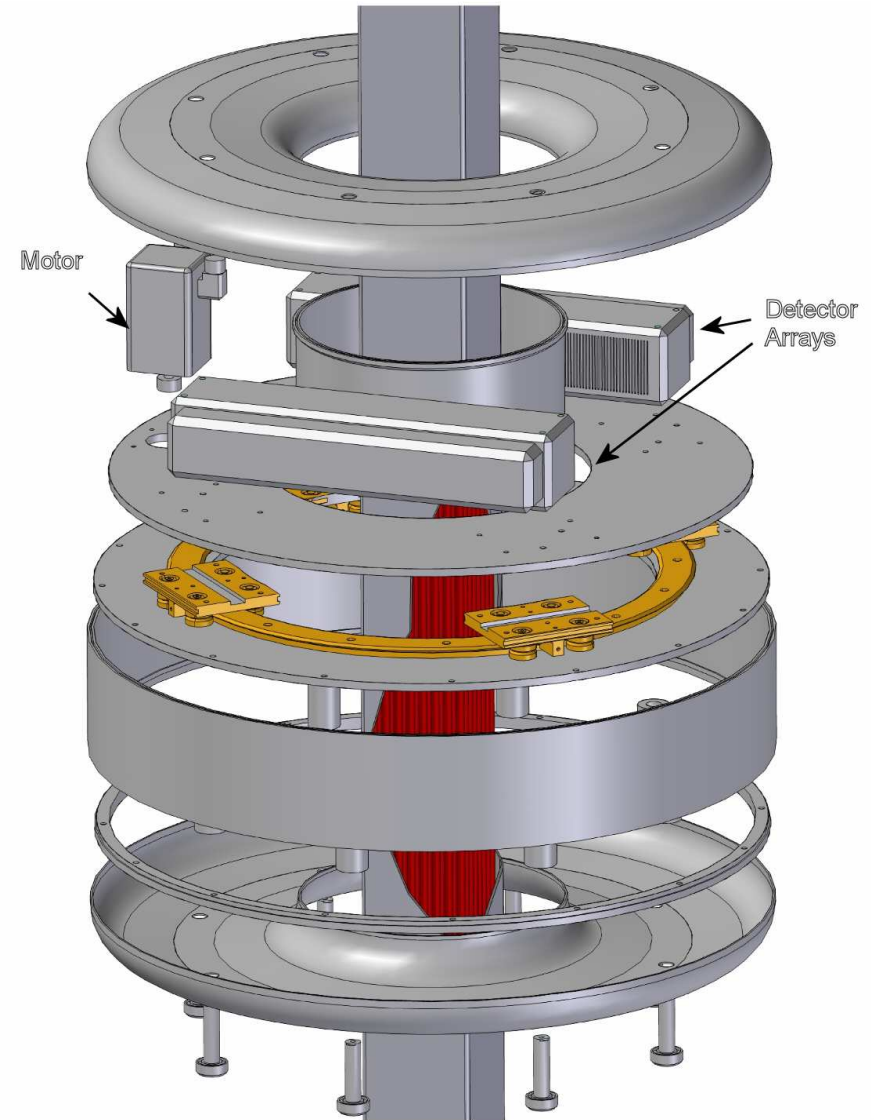

Research at Training Reactor, Hungary

XRF – X-Ray Fluorescence Analysis



Szaloki I, Osan J, Van Grieken RE, X-ray spectrometry, *Analytical Chemistry*, 78, 4069-4096, 2006.

The Training Reactor of TU Budapest, Hungary is open for other countries and universities, and also for post-graduate short courses for senior engineers

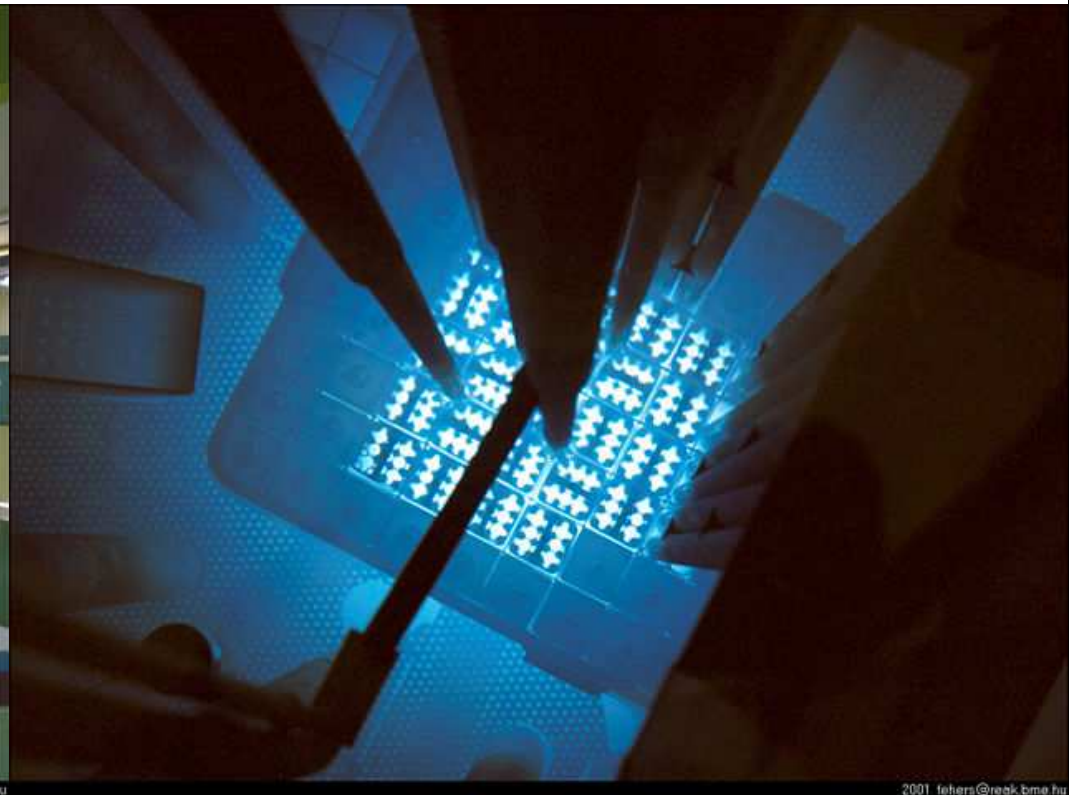

1995-2001 fehers@reak.bme.hu

2001 fehers@reak.bme.hu