



IAEA

Joint FAO/IAEA Division of Nuclear Techniques in Food and Agriculture and FAO/IAEA Agriculture and Biotechnology Laboratory, Seibersdorf

Soils Newsletter

Vol. 30, No. 2

January 2008

<http://www.naweb.iaea.org/nafa/index.html>

ISSN 1011-2650

<http://www.fao.org/waicent/FAOINFO/AGRICULT/Default.htm>



Contents

- To Our Readers 1
- Staff 3
- Staff News 5
- Feature Articles 6
- Technical Cooperation Projects 11
- Forthcoming Events 13
- Past Events 14
- Status of Coordinated Research Projects 18
- Laboratory Activities 20
- Publications 28



Yangjuangou Catchment in Chinese Loess Plateau, where effectiveness of soil conservation measures in reducing soil erosion/sedimentation was assessed by using fallout radionuclides. Photo: Yong Li (IAEA TC Project CPR 5015)

To Our Readers

Belated New Year Greetings to you all. The last month of 2007 was an extremely busy period for the Soil and Water Management & Crop Nutrition (SWMCN) Section. For many of us, the last few days of 2007 were a time to assess the past and celebrate our successes, to meet families and friends and make plans for the future.

Looking back, the Soil and Water Management & Crop Nutrition (SWMCN) Section and the Soil Science Unit (SSU) have successfully achieved their tasks planned for 2007. Both professional staff positions in the SWMCN Section are now filled. Ms. Lee Heng, who previously worked with IAEA in Seibersdorf for seven and a half years and more recently completed one and a half years with FAO, returned to the IAEA as a technical officer (TO) in June 2007. Lee is contributing to the SWMCN subprogramme with expertise in soil physics, agricultural water management and modelling. Mr. Gerd Dercon from the University of Hohenheim (Germany) joined the Section as a TO in October 2007 with expertise in soil conservation measures, crop water productivity, soil fertility and soil quality.



IAEA
International Atomic Energy Agency

The SWMCN subprogramme was also fortunate to receive support from its loyal ex-staff member, Mr. Felipe Zapata who was willing to help beyond the normal call of duty to assist the SWMCN Section in the implementation of its activities. I remain grateful for the dedicated support of both existing and ex-staff team members.

In 2007, the SWMCN subprogramme continued its focus on land degradation, soil conservation measures and agricultural water management. The new Coordinated Research Project (CRP) on Managing Irrigation Water to Enhance Crop Productivity Under Water-Limiting Conditions: A Role for Isotopic Techniques was initiated in 2007 and the first Research Coordination Meeting (RCM) of this CRP was held from 26 to 30 November. Besides this RCM, November and December were also a busy time for the SWMCN subprogramme, with three Consultants Meetings (CM) held in Vienna, Austria on a range of issues that are directly relevant to Member States' concerns. These are: Integrated Approaches for the Assessment of Land Use Impacts on Soil Loss/Sediment Production and Related Environmental Problems (5 to 7 November 2007), Integrated Soil-Water-Plant Solutions for Biomass Production and Environmental Performance as Influenced by Climate Change (12 to 14 November 2007) and Conservation of Soil Water Storage for Biomass Production in Riparian Zones, Natural Wetlands and Strategically Constructed Wetlands (12 to 14 December 2007). These CMs created excellent opportunities and forums for the SWMCN-SSU team and international consultants to identify information gaps and key research areas that will assist in the development of land and water management technology packages to enhance soil carbon sequestration for climate change adaptation, minimize non-point (diffuse) pollution and appropriately target water conservation areas (WSA) within agricultural watersheds for biomass production and environmental quality. Two consultants, Yong Li and Peggy Macgaine who arrived during this busy period also provide valuable inputs to SWMCN-SSU activities.

The SWMCN-SSU team also continued to provide a technical backstop to Technical Cooperation projects (TCPs), covering a range of issues in agriculture such as soil fertility management, land degradation, soil erosion, fertigation and drip irrigation.

2008 will provide the SWMCN subprogramme with additional opportunities for serving the Member States through an increasing numbers of TCPs in agricultural water management and soil conservation. Three RCMs will be held in 2008: Soil, Water and Nutrient Management for Conservation Agriculture (D1.50.09), Selection and Evaluation of Food (Cereal and Legume) Crop Genotypes Tolerant to Low Nitrogen and Phosphorus Soils Through the Use of Isotopic and Nuclear-related Techniques (D1.50.10) and Selection for Greater Agronomic Water Use Efficiency in Wheat and Rice Using Carbon Isotope Discrimination (D1.20.08). The success of these RCMs will depend on the commitment of contract holders, technical contractors, agreement holders and the support of Member States acting as RCM hosts. I would like to thank you all for your support in the months ahead.

My heartfelt congratulations to Mr. Mikha Singh Aulakh of Punjab Agricultural University (PAU), India, one of the contractors of the CRP on Integrated Soil, Water and Nutrient Management for Conservation Agriculture. He has been named by the International Plant Nutrition Institute (USA), as the winner of the '2007 International Plant Nutrition Institute Science Award'. Mr. Aulakh, a Senior Soil Chemist and Professor, is presently Additional Director of Research at Ludhiana (PAU). Mr. Aulakh was honored for his distinguished contributions in global ecological intensification as related to crop production, with important achievements in research, extension and education.

My best wishes to all of the staff and their families and to the readers, consultants, research contractors and counterparts in Member States for a healthy, happy and prosperous 2008.

Long Nguyen

Staff

Joint FAO/IAEA Programme of Nuclear Techniques in Food and Agriculture, Vienna International Centre, Wagramer Strasse 5, P.O. Box 100, A-1400 Vienna, Austria; Telephone (43-1) 2600 + ext.; Fax (43-1) 2600 7; E-mail: Official.Mail@iaea.org

Name	Title	E-Mail Address	Extension
Qu LIANG	Director	Q.Liang@iaea.org	21610

Soil and Water Management and Crop Nutrition Section

Name	Title	E-Mail Address	Extension
Long NGUYEN	Section Head	M.Nguyen@iaea.org	21648
Lee Kheng HENG	Technical Officer	L.Heng@iaea.org	26847
Gerd DERCON	Technical Officer	G.Dercon@iaea.org	21693
Peggy MACAIGNE	Consultant	P.Macaigne@iaea.org	21645
Rosario LEON DE MÜLLNER	Secretary	R.Leon-De-Muellner@iaea.org	21647
Eveline KOPEJTKA	Secretary	E.Kopejtka@iaea.org	21646

FAO/IAEA Agriculture and Biotechnology Laboratory, A-2444 Seibersdorf, Austria

Name	Title	E-Mail Address	Extension
Erik BUSCH-PETERSEN	Head, FAO/IAEA Agriculture and Biotechnology Laboratory	E.Busch.Petersen@iaea.org	28267

Soil Science Unit

Name	Title	E-Mail Address	Extension
Gudni HARDARSON	Unit Head	G.Hardarson@iaea.org	28277
Joseph ADU-GYAMFI	Soil Scientist/Plant Nutritionist	J.Adu-Gyamfi@iaea.org	28263
Lionel MABIT	Soil Scientist	L.Mabit@iaea.org	28271
Leopold MAYR	Senior Laboratory Technician	L.Mayr@iaea.org	28305
José Luis ARRILLAGA	Senior Laboratory Technician	J.L.Arrillaga@iaea.org	28306
Martina AIGNER	Senior Laboratory Technician	M.Aigner@iaea.org	28212
Maria HEILING	Senior Laboratory Technician	M.Heiling@iaea.org	28272
Doris GLUDOVACZ	Laboratory Technician	D.Gludovacz@iaea.org	28272
Arsenio TOLOZA	Laboratory Technician	A.Toloza@iaea.org	28403
Norbert JAGODITSCH	Laboratory Assistant	N.Jagoditsch@iaea.org	28422



L. Nguyen

Soil and Water Management & Crop Nutrition Section (SWMCN)



L. Heng



G. Dercon



E. Kopejtka



R. Leon de Müllner



F. Zapata

Soil and Water Management & Crop Nutrition (SWMCN) Subprogramme



J. Adu-Gyamfi



L. Mayr



G. Hardarson



L. Mabit



J. Arrillaga

Soil Science Unit (SSU)



M. Aigner



D. Gludovacz



M. Heiling



A. Toloza



N. Jagoditsch

Staff News



Mr. Gerd Dercon joined the SWMCN subprogramme on 14 October 2007 after working as a scientist at the Institute of Plant Production and Agroecology in the Tropics and Subtropics, at the University of Hohenheim in Germany. Gerd's expertise is in the areas of soil and water conservation, plant nutrition and soil fertility/quality, and during the last 15 years he has been involved in several research projects around the world. Gerd will act as a technical officer (TO) for both TCPs and CRPs (D1.50.08, D1.50.09 and D1.50.10) linked to soil and water management and crop nutrition. We welcome Gerd to the SWMCN subprogramme and to the team.



Mr. Yong Li joined the SWMCN subprogramme as a consultant for two months from 9 November 2007 until 8 January 2008. He has been working with Mr. Felipe Zapata on finalizing the report of the RCM for the CRP on Assess the Effectiveness of Soil Conservation Techniques for Sustainable Watershed Management Using FRN (D1.50.08). At the same time, he has finalized the Regional Cooperative Agreement (RCA) RAS/5/043 project activities on Sustainable Land Use and Management Strategies for Controlling Soil Erosion and Improving Soil and Water Quality. He assisted in finalizing the reports of the Consultants Meetings on Integrated Approaches for the Assessment of Land Use Impacts on Soil Loss/Sediment Production and Related Environmental Problems (5 to 7 November 2007) and Integrated Soil-Water-Plant Solutions for Biomass Production and Environmental Performance as Influenced by Climate Change (12 to 14 November 2007). He has also been working on other technical issues assigned by the Section Head and we would like to thank Mr. Li for his dedicated assistance and inputs.



Ms. Peggy Macaigne joined the SWMCN subprogramme as a consultant for 12 months from 10 December 2007 until 9 December 2008. Peggy will work with Long Nguyen, Lee Heng and Gudni Hardarson on the use of isotopic techniques in agricultural water management. Welcome Peggy.

Feature Articles

These articles were contributed by some of the scientists visiting the SWMCN Section during the past six months.

Assessment of soil erosion and effectiveness of soil conservation measures in China

Yong Li, Institute of Agro-Environment and Sustainable Development, Chinese Academy of Agricultural Sciences (CAAS), Beijing, China.

The issues

China is one of the countries suffering from the most serious soil erosion in the world. For the Loess Plateau and the North-Eastern China, severe water erosion is the major cause, resulting from the intensive tillage operations and potato growing on steep slopes in the Loess Plateau and downslope cultivation and inappropriate crop rotation in North East-China. For the North China site, wind erosion is the main process, resulting from conventional tillage operations without surface cover. In South West (SW) China, the over-grazing is considered a major cause of accelerated soil and water loss.

Work done

IAEA-funded studies were conducted in the Loess Plateau (Nianzhuang watershed in Yan'an), North China (Fengning site), North East China (Baiquan site), and SW China (Xichang site). Results obtained show that soil erosion rates from cultivated land as measured by fallout radionuclides (^{137}Cs , ^{210}Pb , and ^7Be) are substantial: 40 to 70 $\text{t ha}^{-1} \text{a}^{-1}$ for the Nianzhuang watershed, 24 to 36 $\text{t ha}^{-1} \text{a}^{-1}$ for the Baiquan site, and 16 to 20 $\text{t ha}^{-1} \text{a}^{-1}$ for the Fengning site, whereas soil erosion rates from over-grazed land in the Xichang site are 10 to 35 $\text{t ha}^{-1} \text{a}^{-1}$.

Soil erosion rates, as measured by the fallout radionuclide tracer method, declined by 16 to 80% depending on the type of conservation measure (terraced hillslopes, vegetated hillslopes, contour cultivation and no tillage, species of vegetation) and the studied sites, highlighting the importance of the use of radionuclide tracers in targeting the appropriate soil conservation measures to sites with different levels and types of erosion.

Success stories

The information gained from IAEA-funded studies has been adopted by the Office of the World Bank Project in Baota district, Yan'an for selecting effective soil

conservation measures to control soil erosion. The project area was 800 km^2 (80 000 ha) in the Yanhe River watershed of the Chinese Loess Plateau. Through the use of a cash forest area and the establishment of tree, shrub and grass cover in a structured framework, annual sediment delivery after a six-year period (1998 to 2004) was reduced by 77% compared to that annually produced (8.32 million tons) before the project implementation (1998). Enlargement of the forest area (17 625 ha) by 88% compared with that of 9340 ha at the beginning of the project and the addition of 10 key check dams and 50 silt dams over the six-year period (1998 to 2004) has increased the net income per farmer from 446 Yuan in 1998 to 1754 Yuan in 2004 and grain per capita from 347 kg to 570 kg.

Moreover, through this IAEA-funded CRP project, an analytical laboratory for measuring environmental radioactivity (ALMER) has been established in the Chinese Academy of Agricultural Sciences, which is playing an important role in undertaking the national projects and training scientific staff from the Asia-Pacific and African regions.

Successful collaboration between IAEA and ALMERA-CAAS

Yong Li, Institute of Agro-Environment and Sustainable Development, Chinese Academy of Agricultural Sciences (CAAS), Beijing, China.

ALMERA-CAAS (Analytical Laboratory of Measuring Environmental Radioactivity, the Chinese Academy of Agricultural Sciences) was established in August 2002 at the CAAS. The ALMERA-CAAS focuses on the use of fallout radionuclides (FRN) to assess soil erosion/sedimentation rates and their relation to land and water degradation and carbon storage for sustainable agricultural production and environmental protection. Over the last five years, the ALMERA-CAAS Laboratory collaborating with scientists from Germany, USA and Belgium, and has successfully implemented a series of international research projects (IAEA TC Country Project, RCA and CRP, and projects of the German Research Foundation DFG) and many national projects supported by the Chinese government, and published more than 30 papers in peer-reviewed national and international journals. Major achievements from the

ALMERA-CAAS Laboratory relevant to FRN methodology include:

- 1) Development of a simple device (scraper) to collect soil profile samples at increments of 1 to 2 mm and 2 cm for measuring ^7Be and excess ^{210}Pb activities.
- 2) Development of protocol for assessment of the soil redistribution-soil quality relationship using FRN, which has been adopted by the IAEA RAS5043 Project.
- 3) Development of a laboratory protocol for precisely measuring excess ^{210}Pb activity using gamma spectrometry.
- 4) In-situ gamma-ray spectrometry was found to have the following advantages over traditional laboratory measurements: no time consuming sample collection, prompt availability of results and the ability to obtain an average radionuclide activity over a large area with high precision. Furthermore, repeated measurement of FRN for a study site has the great potential to assess dynamic soil redistribution rates with no need for a reference site, which has been a problem for the laboratory FRN technique. A detailed study on in-situ measurements of FRN is currently being conducted with the support of the National Natural Science Foundation of China.



Figure 1. FRN Measurement at ALMERA of CAAS



Laboratory Gamma Spectrometry
In-situ Gamma Spectrometry Detector: BE5030

The ALMERA-CAAS Laboratory has been actively supporting IAEA technical meetings and training activities. During the period 2002 to 2007, two IAEA RCA project meetings and two training workshops were hosted by the ALMERA.

Fifty scientists from Indonesia, Kenya, Republic of Korea, Laos, Malaysia, Mongolia, Myanmar, Pakistan, Philippines, Sri Lanka, Thailand, and Vietnam have been trained in the ALMERA-CAAS Laboratory through IAEA fellowships, scientific visits, and workshops.

The ALMERA-CAAS Laboratory has also provided analytical services for soil, dust and air samples and expert advice to IAEA's Member States and Chinese institutions. Over the last 5 years, ALMERA-CAAS has implemented more than 500 samples for Australia, Germany, Indonesia, Malaysia and Pakistan, about 1000 samples for Chinese universities and research institutes, and six expert missions to Tajikistan, Mongolia, Pakistan, Thailand and Sri Lanka. Currently, the ALMERA-CAAS Laboratory is organizing inter-laboratory comparison studies among Asian countries and producing scrapers for El Salvador under IAEA TC Projects.



Figure 2. A simple scraper to collect soil profile samples in a arrange of increments of 2 mm to 2 cm for measuring ^7Be , ^{137}Cs and ^{210}Pb activities developed by CAAS-ALMERA in 2003

Fallout radionuclides ^{137}Cs and ^7Be as an important tool to evaluate effectiveness of no-tillage systems in Central-South Chile

P. Schuller¹, D. E. Walling², A. Iroumé¹, A. Castillo¹

¹ Universidad Austral de Chile, Chile, and ² University of Exeter, United Kingdom

The challenge

Since 1970 the process of agricultural intensification has drastically increased soil erosion and associated soil degradation in the coastal mountains of south-central Chile. Due to conventional tillage (with burning of crop residues), over 80% of the soils under agriculture show evidence of compaction below plough depth and erosion rates are described amongst the highest for any agricultural land in Chile.

These problems have prompted a shift from conventional tillage to no-till without burning of crop residues systems. The implementation of no-till systems has been reported to cause significant improvement in soil quality. However, there is still a need to collect information on the precise magnitude of the decrease in soil loss associated with the shift from conventional to no-till systems. Such datasets can provide confirmation of the likely impact, and therefore effectiveness, of such changes in the land tillage system.



Study area in the Coastal Mountains of the Araucanía Region, Chile

The project

The current study developed a simplified method for using ^{137}Cs depth distribution datasets to estimate soil loss or accumulation at a sampling point under conventional tillage and after the shift to a no-till system. Previous applications of ^{137}Cs measurements had been limited to the estimation of erosion rates during the period extending from the beginning of fallout receipt to the time of sampling. The new procedure allows the

change in erosion rates associated with a shift in land tillage practices to be estimated. It represents an innovative application of ^{137}Cs measurements in soil erosion research. In an additional study to assess no-till systems with and without burning of crop residues after harvesting, ^7Be was used to quantify the erosion that occurred within the same field area, as a result of burning and a period of extreme rainfall (400 mm in 27 days, May 2005).

The studied site, characterized by moderate slope gradients (11%), is located in the Coastal Mountains of the Araucanía Region, Chile. The soil is Ultisols (Typic Hapludult), and the area has a temperate climate and a mean annual precipitation of 1100 mm year⁻¹.

Main findings

The obtained fallout radionuclide (FRN) data showed that 16 years after implementing the no-till system, there was a reduction in the erosion rate of about 87% (from 11 t ha⁻¹ year⁻¹ to 1.4 t ha⁻¹ year⁻¹). In addition, the proportion of the study area, subject to erosion, decreased from 100% to 57%.

The net erosion associated with crop residue burning and an extreme rainfall event (400 mm in 27 days occurring in May 2005) as estimated from the FRN was approximately 12 t ha⁻¹. This indicated that large proportions of soil and ashes were mobilized by erosion and transported beyond the study area during the period of heavy rainfall.

Comparing these results with those estimated for the medium long term net erosion rate (1.4 t ha⁻¹ year⁻¹) during a prolonged period of no-till without the burning of crop residues, it would appear that burning in autumn is a highly undesirable practice, since it could promote soil loss in the following rainy season, especially under high magnitude erosive events.

These results have been provided to the Chilean Government and regional officers, indicating that the adoption of a no-till system without burning of crop residues can make crop production in Southern Chile more sustainable and environmentally friendly.

This practice will also lead to reduced sediment transfer to local watercourses, reducing the offsite effects of soil erosion and, more particularly, diffuse source pollution associated with sediment inputs to the stream network.

How nuclear techniques helped in assessing the impact of wildfire on erosion, sedimentation and downstream water quality in Australia

Wallbrink, P., Wilkinson, S., Blake, W., Doer, S., Shakesby, R.

Commonwealth Scientific Industrial Research Organization (CSIRO), Canberra, Australia

The challenge

Wildfires occur naturally in many countries and continents. However, they can have serious impacts on human infrastructure, including the provision of fresh water supply. Worldwide, many cities have water supply reservoirs that are forested, prone to wildfire, and thus potentially susceptible to the negative impacts of fires on reservoir water quality. Climate change is also likely to increase the prevalence of fires in those countries that will suffer reduced rainfall patterns. Consequently, it is very important to know in what ways wildfires will impact on reservoirs.



View of the wildfire in the region close to Sydney, Australia

The project

The CSIRO team used fallout radionuclides and geomorphologic methods to investigate the impact on water quality of sediments and nutrients released following a catastrophic wildfire in Warragamba reservoir, which is the principal water supply for Sydney (with a population of 3.5 million) in NSW, Australia. The project was carried out in three phases:

- 1) Quantifying the amount of sediments and nutrients transferred from burnt hillslopes to streams after the fire,
- 2) Characterizing the nature, extent and timeframe of the sediment impact on the downstream streams and,
- 3) Assessing the impact of this fire event on the overall amount of sediment and nutrients already stored in the reservoir.

Main findings

Tracer budgets showed that significant amounts of sediment and attached nutrients were eroded from burnt hillslopes in the months following the fire event. Concentrations of fine fused aggregates with high nutrient concentrations were prevalent. Comparison of concentrations of ^{137}Cs and $^{210}\text{Pb}_{\text{ex}}$ on eroded surface soil and river sediments showed that a high proportion of river sediment was derived from surface erosion of hillslopes after fire, in contrast to the pre-fire sediment sources which were dominated by erosion of sub-surface

material from rivers and gullies. The post-fire nutrient concentration of river sediment was many times that of pre-fire. The size of the area burnt was shown to control the amount of surface erosion and delivery of high nutrient materials. The total suspended solids, Nitrogen and Phosphorus concentrations in post-fire runoff events were one to two orders of magnitude larger than in pre-fire conditions. The characteristics of post-fire river sediment only returned to pre-fire conditions over four years.

The post-fire FRN data indicates that nutrient concentration in river sediment was many times that of pre-fire, resulting from surface erosion of burnt hillslopes. Given the potential for nutrient-fuelled negative water quality impacts such as algal blooms, it is imperative to undertake monitoring after fires and to manage for post-fire sediment and nutrient delivery to reservoirs.

How fallout ^{137}Cs can help in improving the management and soil/water quality of semiarid rangelands in Arizona, USA

Ritchie, J.

USDA ARS Hydrology and Remote Sensing Laboratory, USA

The challenge

Degradation of semiarid and arid rangelands is a major concern and is usually described in terms of soil movement/erosion and changing plant communities. Understanding the patterns of soil erosion, soil redistribution, and sediment yield are key factors for monitoring and assessing soil quality, rangeland condition, water quality, and managing semiarid rangelands. Maintaining or improving soil quality or rangeland conditions requires managing soil erosion and soil organic carbon movement and losses at the field and watershed levels. The stability of semiarid rangeland ecosystems has been defined as the capability of a site to limit redistribution and loss of soil resources (including nutrients and organic matter) by wind and water.

The project

This research project developed sediment budgets and identified potential sediment sources with fingerprinting using ^{137}Cs and other soil properties in a series of small semiarid rangeland watersheds on the USDA ARS Walnut Gulch Experimental Watershed near Tombstone, Arizona, USA.



Extreme runoff event at outlet flume at the USDA ARS Walnut Gulch Experimental Watershed

Main findings

Sediment budgets measured by using ^{137}Cs inventories for a small shrub and a small grass watershed found that eroding areas in these watersheds were losing 5.6 and 3.2 $\text{t ha}^{-1} \text{a}^{-1}$, respectively. However, a sediment budget for each of the small watersheds, including depositional areas, found net soil loss to be 4.3 $\text{t ha}^{-1} \text{a}^{-1}$ from the shrub watershed and 0 $\text{t ha}^{-1} \text{a}^{-1}$ from the grass

watershed. Thus soil redistribution within the watershed is a major factor in the grassland. Fingerprinting also showed that in general, suspended sediments from shrub dominated watersheds were contributing over 80% of the suspended sediments exported from the watershed. In addition, the study linked most of the suspended sediment to streambed and gully erosion rather than sheet erosion. The ability to identify primary sediment sources in watersheds contributes to a more efficient implementation of management practices to reduce pollutant loads, both suspended sediments and chemicals, from watersheds. These studies suggest that management of these semiarid rangelands must consider techniques that will protect grass dominated areas from shrub invasion.

Technical Cooperation Projects

Operational Projects and Technical Officers responsible for implementation

Project Number	Title	Technical Officer
AFG5003	Sustainable increase in crop production in Afghanistan	L. Nguyen/P. Lagoda
ALG5020	Combating desertification	G. Dercon
ALG5021	Optimising irrigation systems and surface water management	L. Heng
ALG5022	Nuclear techniques for sustainable use of saline groundwater and wastelands for plant production	L. Heng
ANG5005	Effect of biofertilizer and inorganic fertilizer uses on the growth and yield of maize and bean in Ferralitic soils of Huambo	G. Hardarson
BGD5026	Increasing agricultural production in the costal area through improved crop, water and soil management	Q. Shu /J. Adu-Gyamfi
CMR5013	Use of nuclear techniques in soil, nutrient and water studies	L. Heng
CMR5016	Development of N and P fertilizer management for Sustainable Intensification of agricultural production in Cameroon	L. Heng
CHI5048	Integrated watershed management for the sustainability of agricultural lands	I. Ferris/ L. Mabit
CPR5015	Assessment of soil erosion and effectiveness of soil conservation	G. Dercon
ECU5022	Efficient use of nitrogen fertilizers in flower production	L. Heng
ECU5024	Improving Productivity of the African Palm through Better Fertilization and Water Management Practices	G. Dercon
ELS8009	Study of sedimentation in the reservoirs of four CEL hydroelectric power stations	T. Vitvar/G. Dercon
ERI5004	Improving crop productivity and combating desertification	P. Lagoda/J. Adu-Gyamfi
GHA5032	Enhancing production and use of cassava	L. Heng
HAI5003	Enhancing crop productivity through the application of isotope nuclear techniques	L. Heng
INS5035	Application of Nuclear Techniques for Screening and Improving Cash Crop Plants in Coastal Saline Lands	Q. Shu/G. Dercon
IVC5029	Improvement of yield in plantain and cassava through the use of legume cover crops	G. Hardarson
JAM5009	Development of soil fertility management	L. Heng
KEN5026	Isotope techniques for assessment of water and nitrogen use efficiency in cowpea/maize intercropping systems	J. Adu-Gyamfi
MAG5014	Use of environmental radioisotopes for the assessment of soil erosion and sedimentation in the province of Antananarivo, Madagascar	L. Mabit
MAG5015	Optimization of phosphate fertilization of Ferralsols (classically deeply weathered red or yellow soils found in humid east Madagascar) in the highlands of Madagascar	G. Dercon
MAR5014	Management Practices for Increased Efficiency of Fertilizers and Improved Productivity of Saline Soils	L. Nguyen

Project Number	Title	Technical Officer
MAR5017	Investigating the N dynamics in the crop-soil system of a multiple cropping system to optimize fertilizer use	L. Nguyen
MLI5021	Sustainable intensification and diversification of sorghum production systems in the southern zone of Mali, Phase I	L. Heng
MLI5022	Assessment of soil erosion and sedimentation in the Niger watershed with the use of radioisotopes, Phase I	L. Mabit
MON5014	Application of Isotopes in soil and plant studies	G. Hardarson
MON5015	Implementation of the fallout radionuclide technique for erosion measurement	G. Dercon
NAM5008	Increasing crop productivity and resource use efficiency in the northern communal areas	L. Heng
NER5012	Improvement of the productivity and sustainability of cowpea with finger millet	G. Dercon/M. Spencer
PHI5031	Assessment of erosion and sedimentation processes for effective formulation of soil conservation and water quality protection measures	G. Dercon
QAT5002	Developing Biosaline Agriculture in Salt-affected Areas in Qatar	P. Lagoda/L. Nguyen
RAS5043	Sustainable land use and management strategies for controlling soil erosion and improving soil and water quality	G. Dercon
RLA5050	Strengthening laboratory capacity to assess the implementation of good agricultural practices in the production of fruit and vegetables in Latin America	I. Ferris/G. Dercon
SAU5003	Improving Fertilization under Saline Conditions for Sustainable Crop Production	P. Lagoda/L. Nguyen
SEN5030	Integrated approach to develop sustainable agriculture in Senegal	G.. Dercon/M. Spencer
SEY5002	Nutrient and Moisture Determination in the Soils of Seychelles to Establish a Programme of Fertilization and Irrigation in the Face of Limited Water Supply and Low Soil Fertility	L. Heng
SIL5008	Contribution of nitrogen fixing legumes to soil fertility in rice-based cropping systems	G. Hardarson
SLO5002	Protecting groundwater and soil against pollutants using nuclear techniques	J. Adu-Gyamfi/ I. Ferris
SRL5038	Application of isotopes for soil erosion studies	G. Dercon
SUD5030	Increasing productivity of selected crops using nuclear related techniques	Q. Shu/J. Adu-Gyamfi
TAD5002	Assessment of soil erosion and sedimentation for Land Use	G. Dercon
TUR5024	Improving crop productivity through nuclear and related techniques	L. Nguyen
UGA5029	Developing soil conservation strategies	G. Dercon
YEM5002	Drip Irrigation and Fertigation for Improved Agricultural Productivity	J. Adu-Gyamfi
ZAI5017	Use of isotope techniques in relation with the nitrogen dynamics and the quality of organic plant material in agricultural soil management	G. Dercon
ZIM5011	Combating desertification in agricultural lands	L. Heng

Forthcoming Events

FAO/IAEA Events

Third Research Coordination Meeting (RCM) of the Coordinated Research Project (CRP) on Soil, Water and Nutrient Management for Conservation Agriculture, (D1.50.09)

Scientific Secretary: Gerd Dercon

The extension of this CRP until completion in 2009 was approved in September 2007 after the submission of the Mid-Term Project Report.

The third RCM of this CRP will be held from 14 to 18 April 2008 in Ankara, Turkey. The local organizer of the meeting is Mr. Mahmut Basri Halitligil. Preparatory work to organize the meeting is underway.

It is expected that seven contract holders, two technical contractors and one agreement holder will attend the meeting. The main objective of the third RCM will be to present and evaluate the results obtained since the second RCM and to outline further issues and priorities for completion of the CRP, especially strategies for summarizing, publishing and disseminating the results.

Second Research Coordination Meeting (RCM) of the Coordinated Research Project (CRP) on Selection and Evaluation of Food (Cereal and Legume) Crop Genotypes Tolerant to Low Nitrogen and Phosphorus Soils through the Use of Isotopic and Nuclear-related Techniques, (D1.50.10)

Scientific Secretaries: Joseph Adu-Gyamfi and Lee Kheng Heng

The second RCM is planned for 21 to 25 April 2008 and will be held in Morelia, Mexico. The main objective of this RCM will be to present and evaluate the results obtained since the first RCM, review workplans, discuss characterization (soil physical and chemical properties of the selected sites) and progress towards reaching the overall specific objectives of the CRP.

Non-FAO/IAEA Events 2008

- High resolution digital soil sensing and mapping, 5 to 8 February, Sydney, Australia. http://www.iuss.org/HRDSM_Flyer3.pdf
- 2008 IFA Technical Symposium 'Food, Fuel and Climate Change: Challenges for the Fertilizer Industry', 10 to 14 March, Sao Paulo, Brazil. <http://www.fertilizer.org/ifa/confifaall.asp>
- IUSS Inter-Congress meeting, 30 June to 4 July, Brisbane, Australia.
- 33rd International Geological Congress, 5 to 14 August, Oslo, Norway. <http://www.33igc.org>
- EUROSOIL 2008. SOIL-SOCIETY-ENVIRONMENT. 25 to 29 August, Vienna, Austria. <http://www.ecsss.net/web/frontend/view.php>
- 13th International Conference on soil micromorphology, 11 to 16 September, Chengdu, China. <http://icsm.imde.ac.cn>
- 5th International conference on land degradation, 18 to 22 September, Valenzano, Bari, Italy. <http://www.emwis.net/thematicdirs/events/sev966759>
- International congress of irrigation and drainage, 13 to 19 October, Lahore Pakistan. <http://www.icid.org/conf.html>
- 16th International Symposium of the CIEC: Mineral versus Organic Fertilization, Conflict or Synergism?, 16 to 19 September, Ghent, Belgium www.soilman.ugent.be/ciec
- TFI-World Fertilizer Conference, 17 to 20 September, Boston, USA. www.tfi.org
- INI-4th International Nitrogen Conference, 1 to 5 October, Bahia, Brazil. www.nitrogen2007.com
- ASA-CSSA-SSSA International Annual Meeting, 26 to 30 October, USA <http://www.iuss.org/bull110files/upcoming.htm>
- NZ/Aust Soils Conference "Soil - the living skin of Planet Earth", 1 to 5 December, Massey University, Palmerston North, New Zealand. <http://conferences.massey.ac.nz/Soils2008/index.htm>

Past Events

IAEA Events

IAEA General Conference Display by the SWMCN subprogramme

The 51st General Conference of the IAEA was held from 17 to 23 September 2007. Staff of the SWMCN subprogramme manned the Department of Nuclear Sciences and Application (NSA) display booth during the week, and on Tuesday, 18 September (NAFA theme day) they manned the NAFA display booth, which included publications and promotional material (printed and audio-visual) from all NAFA subprogrammes. Three posters on 'Nuclear techniques for soil erosion control', 'Bringing hope to the drylands' and 'More Crops per Drop' were prepared and displayed by the SWMCN subprogramme. In addition to the posters, the Soil Science Unit mounted a display to demonstrate the interactive effects of fertilizer nitrogen (N) and phosphorus (P) on the root development and growth of cereals and legumes in soil and solution culture media. Maize (cereal) and common beans (legume) were grown in transparent glass tubes in either soil or nutrient solution.



Live display of soil-nutrient-plant interaction at the General Conference

Four treatments were applied to the studied soil

- 1) No N and P applied;
- 2) N applied at 200 kg ha⁻¹ but no P applied;
- 3) P applied at 60 kg ha⁻¹ but no N applied;
- 4) N applied at 200 kg ha⁻¹ and P at 60 kg ha⁻¹.

Similar treatments were used for the solution culture display, except that the N treatment was 20 mg L⁻¹ and the P 5 L⁻¹ in the same combinations as the soil culture. The display clearly demonstrated that the application of P fertilizer enhanced root development and crop growth through enhanced N uptake by crops. Crop growth and root development were more impaired when no P was applied (despite the application of N) than in the treatments where P was applied but no N. The effect of no added P on plant growth was more severe in the cereal than in the legume.



The DG of FAO and Mr. Liang Qu, Director of the Joint FAO/IAEA Joint Programme at the IAEA General Conference Poster Display

FAO/IAEA Events

Fourth and Final Research Coordination Meeting (RCM) of the Coordinated Research Project (CRP) on Assess the Effectiveness of Soil Conservation Techniques for Sustainable Watershed Management Using Fallout Radionuclides, 15 to 19 November, 2007, Vienna, Austria, (D1.50.08)

Scientific Secretary: Felipe Zapata

The final Research Coordination Meeting of this CRP was held in the IAEA Headquarters in Vienna from 15 to 19 October 2007. The main purpose of this meeting was:

- 1) to present and discuss the results of the research carried out in the course of the CRP,
- 2) to evaluate project achievements in accordance with the project objectives and expected outputs,

- 3) to review the manuscripts prepared for the production of the IAEA TEC-DOC publication.

All of the chief scientific investigators: eleven research contractors from Brazil, Chile, China (two), Morocco, Pakistan, Poland, the Russian Federation, Romania, Turkey and Vietnam; two technical contractors from Austria and the UK and four agreement holders from Australia, Canada, Japan and USA attended the meeting.

In addition there were three observers: Mr. W. Blake, Plymouth University, UK, Mr. H. Kato, Japan and Mr. G. Wurm, Austria. IAEA staff of the Section and Unit also participated. The Section Head, Mr. Long Nguyen, opened the meeting and highlighted the role of nuclear techniques in providing information on soil erosion and the resulting deposition in watersheds to underpin the selection of appropriate and cost-effective soil conservation measures.



Participants at the final RCM of the CRP D1.50.08

First Research Coordination Meeting (RCM) of the Coordinated Research Project (CRP) on Managing Irrigation Water to Enhance Crop Productivity under Water-Limiting Conditions: a Role for Isotopic Techniques, 26 to 30 November 2007, Vienna, Austria, (D1.20.09)

Scientific Secretaries: Long Nguyen and Lee Heng

The main purpose of this RCM was to examine the experimental design and workplan for the project of each participant and to establish standardized methodologies and protocols to be used by all participants in accordance with the workplan and objectives of the CRP.

A one-day workshop was organized at the Agency's Laboratories in Seibersdorf to brief the participants on laboratory activities related to the use of isotopic techniques for soil water measurements and evapotranspiration studies, and to discuss isotopic data analysis.

Thirteen participants, consisting of nine research contractors (two from China and one from each of the seven countries, Burkina Faso, Malawi, Morocco, Pakistan, Turkey, Vietnam and Zambia), two technical contractors from USA, and two agreement holders from Austria and Spain attended the first RCM of this CRP.



Participants of the first RCM of the CRP D1.20.09

Consultants Meeting (CM) on Integrated Approaches for the Assessment of Land Use Impacts on Soil Loss/Sediment Production and Related Environmental Problems, 5 to 7 November 2007, Vienna, Austria.

Scientific Secretaries: Long Nguyen and Gerd Dercon

The CM attended by five consultants from China, New Zealand, the United Kingdom, the USA and France was held at the Vienna International Centre.

The objectives of this CM were:

- To review recent advances and future trends in the use of isotopic, nuclear and related conventional techniques to investigate the production, mobilization, transfer and storage of sediment, to establish watershed sediment budgets and to assess sediment-associated pollution problems at the watershed scale.
- To identify key research needs in developing and improved understanding of watershed sediment budgets and the source identification, transport and storage of sediment and sediment-associated contamination problems by exploiting the use of nuclear techniques.
- To plan a Coordinated Research Project that would develop tools (knowledge, techniques, approaches/strategies and protocols) for watershed-scale assessment of soil loss/sediment transport to support the development of improved land management and sediment control strategies.

The outcome of this CM was the development of a proposal for a CRP entitled: 'Tracking sediment sources and transfers at the watershed scale using isotopic and nuclear techniques, to ensure sustainable agriculture and environmental protection'.

Consultants Meeting on Integrated Soil-Water-Plant Solutions for Biomass Production and Environmental Performance as Influenced by Climate Changes, 12 to 14 November 2007, Vienna, Austria.

This CM consisting of five consultants from Austria, China, France, the United Kingdom and the USA was held at the Vienna International Centre.

Scientific Secretary: Long Nguyen

The objectives of this CM were:

- To identify land management practices that mitigate climate change and advance food security.
- To identify adaptation management strategies in agriculture to climate change and biofuel production.

- To review impacts of climate change and biofuel production on soil health and environmental management.
- To review recent advances in the use of isotopic and nuclear techniques in climate adaptation/mitigation measures.

The consultants identified the following key research areas that are important in climate mitigation/adaptation and land carbon sequestration:

- 1) Carbon sequestration in agro-ecosystems for enhancing food production and mitigating climate change,
- 2) Ecosystem carbon budgeting and environmental sustainability for biofuel production,
- 3) Restoration of degraded/desertified soils to mitigate climate change and
- 4) Selecting and evaluating germplasm from farming systems under extreme climate conditions for sustainable food and biomass production.

The fourth research area could be jointly explored with the Plant Breeding and Genetics Section.

Consultants Meeting on Conservation of Soil Water Storage for Biomass Production in Riparian Zones, Natural Wetlands and Strategically Constructed Wetlands, 12 to 14 December 2007, Vienna, Austria.

Scientific Secretaries: Lee Heng and Long Nguyen

Five consultants from Canada, the United Kingdom, France, Estonia, and the USA plus three observers from France, Austria and China attended this CM.

The objectives of this CM were:

- To obtain an inventory of different methods of water conservation systems (WCS) that can be strategically deployed within agricultural catchments to enhance water quantity and quality for biomass production and environmental sustainability.
- To review recent advances in the use of nuclear, isotopic, and related technologies in the sustainable management and conservation of water in these WCS systems for ecological and agricultural purposes.
- To identify critical areas where further knowledge is required to enhance conservation of soil water storage for biomass production through strategic placing of WCS in agricultural catchments.

The outcome of this CM was the development of a proposal for a CRP entitled 'Strategic placement and evaluation of water conservation areas in agricultural catchments for biomass production, water quality and food security', to assess and enhance ecosystem services provided by wetlands, ponds and riparian zones for

improving water storage and quality in agricultural catchments.

NON FAO/IAEA Events

European Training Course for Gamma Vision Software, 24 to 28 September 2007, Meerbusch, Germany

Arsenio Toloza (Soil Science Unit)

Mr. Arsenio Toloza, in charge of maintenance and radioisotope determinations at the Soil Science Unit, participated in the European Training Course for Gamma Vision Software which was held in Meerbusch, Germany to improve his knowledge in evaluating and analyzing spectrum, reviewing report and display result graphically.

Twelve participants from Sweden, Norway, the Netherlands, Germany, and Austria attended this five-day Training Course. The course was conducted by instructors involved in the design and programming of Gamma Vision.

Gamma Vision is one of the main high purity germanium (HPGe) spectroscopy software programmes. This software controls the acquisition and analysis of data collected from HPGe detectors and it allows identification of nuclides by gamma energy emission to quantify the activity concentrations. It is a fully functional windows programme for any PC environment and it includes patented True Coincidence Summing Corrections and Auto Calibration. It is compatible with a complete range of electronics and HPGe detectors.



Participants at the European Training Course for Gamma Vision Software 2007

The International Annual Meetings of the American Society of Agronomy (ASA), Crop Science Society of America (CSSA) and Soil Science Society of America (SSSA), 4 to 8 November 2007, New Orleans, Louisiana, USA

Lee Heng (SWMCN Section)

Lee Heng attended and presented two oral papers at the A-3 Symposium on 'Yield Response to Water: Examination of the Role of Crop Models in Predicting Water Use Efficiency'.

Both of Lee Heng's oral papers are related to FAO's AquaCrop model, one paper was entitled 'Calibration and testing of FAO AquaCrop model for rainfed and irrigated maize' and the second paper was entitled 'Productivity of soybean-based systems in semi-arid tropics - Testing with AquaCrop'.

Non-FAO/IAEA Meetings

The 10th International Symposium on River Sedimentation, 1 to 4 August 2007, Moscow, Russia

Lionel Mabit (*Soil Science Unit*)

The International Symposium on River Sedimentation (ISRS) in Moscow was the triennial conference series initiated in 1980 by the Chinese Hydraulic Engineering Society and supported by the United Nations Educational, Scientific and Cultural Organization (UNESCO). The central theme of the 10th ISRS was the Effects of River Sediment and Channel Processes on Social, Economical, and Environmental Safety. This conference, organized by the M.V. Lomonosov Moscow State University, was sponsored by UNESCO, the Prince Sultan Bin Abdulaziz International Prize for Water, the Federal Agency of Water Resources, the Russian Federation Ministry of Natural Resources, the Federal Agency of Science and Innovations and about 10 other institutes in Russia.

The 10th ISRS objectives were to focus on sediment transport and accumulation across agriculture landscapes and its subsequent impact on riverbed and water reservoirs. The 10th ISRS included 349 papers from 40 different countries. Several papers on the use of FRN methodology to measure soil erosion and sedimentation across time were presented by participants. During session one (Processes within drainage basins as sources of river sediment: study, modelling, and forecasting under natural and anthropogenic conditions). Lionel Mabit presented an oral paper entitled 'Use of Geostatistics to Establish Soil Movement Maps and Sediment Budgets Using Fallout Radionuclides (FRN)'.

Status of Coordinated Research Projects (CRPs)

Selection for Greater Agronomic Water Use Efficiency in Wheat And Rice Using Carbon Isotope Discrimination (D1.20.08)

Technical Officer: Lee Heng

This CRP had its third research coordination meeting (RCM) in Yinchuan, China in June 2007 with Phil Chalk acting as the scientific secretary. The RCM was attended by nine contract holders, two technical contractors and one agreement holder. The meeting concluded that there is a need to minimise variation in many yield-influencing traits such as height and phenology if associations between them and $\Delta^{13}\text{C}$ are to be established. This could be achieved using populations of lines derived from crosses of adapted parents. The meeting also concluded that cheaper traits (such as grain and leaf ash) related to carbon isotope discrimination are needed if selection for greater agronomic water use efficiency is to be a routine breeding objective, as the measurement of carbon isotope composition is expensive.

Currently all nine research contractors and one of the two technical contractors have been renewed for the last contract. The fourth and final meeting will be held at IAEA Headquarters, Vienna in November 2008. A circular will be sent to all participants by June 2008 informing them about the meeting.

Conservation Measures for Sustainable Watershed Management Using Fallout Radionuclides (D1.50.08)

Technical Officer: Felipe Zapata

The overall objective of this CRP is to develop diagnostic tools for assessing soil erosion and sedimentation processes and effective soil conservation measures for sustainable watershed management. In this context, the participants are further developing fallout radionuclide methodologies with particular emphasis on the combined use of ^{137}Cs , $^{210}\text{Pb}_{\text{exc}}$ and ^7Be for measuring soil erosion and sedimentation over several spatial and temporal scales.

Eleven contract holders from Brazil, Chile, China (two), Morocco, Pakistan, Poland, Romania, the Russian Federation, Turkey and Vietnam, two technical contractors (Austria and the UK) and five agreement holders (Australia, Canada, Japan, Switzerland and the USA) are participating in this CRP.

The first, second and third RCMs were held in Vienna, March 2003, Istanbul, October 2004 and Vienna, March 2006 respectively.

Participants have generated a wealth of information in their investigations conducted under the CRP. The results have already been published in a number of technical

reports and/or peer-reviewed scientific journals. Presentations have also been made at national and international scientific meetings. Further efforts to disseminate the results focused on the preparation of manuscripts for the production of an IAEA TEC-DOC.

Integrated Soil, Water and Nutrient Management in Conservation Agriculture (D1.50.09)

Technical Officer: Felipe Zapata

The overall objective of this CRP is to enhance the productivity and sustainability of farming systems through a better understanding of the principles and practice of conservation agriculture. This should be achieved through the specific objective, which is to quantify the individual and interactive effects of conservation tillage practices, residue management, crop rotations, nutrient and water inputs to increase soil organic matter, resource use efficiency, agricultural productivity and environmental quality.

This CRP has a total of 11 participants comprising eight research contractors from Argentina, Brazil, India, Morocco, Pakistan, Turkey, Uganda and Uzbekistan, two technical contractors (Australia and Chile) and one agreement holder (Mr. M. Pulleman, CIMMYT-Mexico). Mr. B. Vanlauwe, former agreement holder has been awarded an individual contract to conduct research on Evaluation of C and N dynamics in long term trials in Sub-Saharan Africa focusing on tillage, residue management and rotational effects.

The first and second RCMs were held in Vienna, June 2005 and Rabat (Morocco), September 2006.

The mid-term review of the CRP was carried out in September 2007 and the extension of the CRP to five years was approved. Progress reports and requests for contract renewal in 2008 will be evaluated in November-December this year.

The third RCM will be held from 25 to 29 February 2008 in Ankara, Turkey. The local organizer of the meeting is Mr. Mahmut Basri Halitligil. The fourth and Final RCM is scheduled to be held in the second semester 2009 at the IAEA's Headquarters in Vienna.

Selection and Evaluation of Food (Cereal and Legume) Crop Genotypes Tolerant to Low Nitrogen and Phosphorus Soils Through the Use of Isotopic and Nuclear-related Techniques (D1.50.10)

Technical Officers: Joseph Adu-Gyamfi and Gerd Dercon

The report of the first RCM held at the IAEA, Vienna, from 16 to 20 October 2006 was finalized and sent to the 10 research contract holders from Burkina Faso, Brazil, Cameroon, China, Cuba, Ghana, Malaysia, Mexico, Mozambique and Sierra Leone, five agreement holders from Australia (UWA), Benin (WARDA), France (ENSA), Kenya (TSBF-CIAT) and Nigeria (IITA) and two Technical Contractors from Germany (University of Hanover) and the USA (University of Pennsylvania). Evaluation of the requests for contract renewals (June 2007 to May 2008) has been completed. The second RCM will be held from 21 to 25 April 2008 in Morelia, Mexico.

Laboratory Activities

Research

Evaluation of the initial fallout of ^{137}Cs and characterisation of a reference site in the Mistelbach watershed (Austria)

L. Mabit (Soil Science Unit), A. Klik ⁽¹⁾ A. Toloza (Soil Science Unit), A. Geisler ⁽²⁾ and U.C. Gerstmann ⁽²⁾

⁽¹⁾ Universität für Bodenkultur (BOKU), Department für Wasser-Atmosphäre-Umwelt, Institute of Hydraulics and Rural Water Management, Vienna, Austria.

⁽²⁾ GSF-National Research Center for Environment and Health, Institute of Radiation Protection, Neuherberg, Germany

Conventional sediment loading measurements have been carried out for nearly ten years by Boku University on plots in the Mistelbach watershed (18 ha) located 60 km north of Vienna in Austria. This site was therefore selected for a comparison of the magnitude and spatial distribution of soil erosion/deposition using radionuclide measurements and conventional measurement techniques.

Results obtained from an undisturbed forest site which is over 20 years old (a reference site) indicate an exponential decrease of the ^{137}Cs activity across the soil profile with 90 % of the cesium in the first 15 cm.

The ^{137}Cs activity of the 76 forested samples ranged from 1123 to 3354 Bq m⁻². The average value of the base level corresponding to the residual amount left from the historic ^{137}Cs fallout in the absence of erosion or deposition reached 1954 ± 91 Bq m⁻² (mean $\pm 95\%$ confidence interval) with a coefficient of variation of 20.4%. This activity ($< 2\text{ kBq m}^{-2}$) demonstrates a negligible amount of Chernobyl fallout contribution in the study area and is considered as an estimated ^{137}Cs base level which will be used in our future investigations to assess sedimentation and erosion rates in the Mistelbach watershed.

Advantages and limitations of ^{137}Cs , ^{210}Pb and ^7Be methodologies for assessing erosion and sedimentation processes

Lionel Mabit (Soil Science Unit), Moncef Benmansour ⁽¹⁾, Gyula Kis-Benedek (Chemistry Unit) and Philippe Bonté ⁽²⁾

⁽¹⁾ Centre national de l'énergie, des sciences et des techniques nucléaires (CNESTEN), Rabat, Morocco

⁽²⁾ Laboratoire des sciences du climat et de l'environnement, (LSCE), Commissariat à l'énergie atomique (CEA), Centre national de la recherche scientifique (CNRS), Gif sur Yvette, France

As demonstrated by around 4000 research papers published, fallout radionuclides 'FRN' (^{137}Cs , ^{210}Pb and ^7Be) have been successfully used as soil redistribution tracers for measuring erosion and sedimentation processes. The following table presents the advantages and limitations of each of the FRNs as soil redistribution tracers.

Comparative advantages and limitations of ^{137}Cs , ^{210}Pb and ^7Be methodologies

	Origin	Energy emission (KeV)	Half-life	Time span	Erosion and sediment assessment	Sample collection	Area tested	Equipment needs	Laboratory measurement	In situ measurement	Sediment dating
^{137}Cs	artificial	662	30.17 years	50 years	mid term	simple	plot to large watershed	Normal HPGe γ detector	easy	easy	possible
^{210}Pb	natural geogenic	46	22.8 years	100 years	long term	simple	plot to watershed	Broad energy range HPGe γ detector	more difficult	not possible	possible
^7Be	natural cosmogenic	477	53.3 days	≤ 6 months	short term	require fine increment collection	local scale, plot to field	Normal HPGe γ detector	easy	require at least double counting time in the field than ^{137}Cs	possible

¹³⁷Cs (Caesium-137 or Cesium-137)

- ¹³⁷Cs is the most well known FRN, with a long half life ($t_{1/2} = 30.17$ years), coming from thermonuclear weapon tests or from nuclear accidents. In general, there is more ¹³⁷Cs in northern hemisphere than in southern hemisphere.
- The ¹³⁷Cs-method can be used to assess annual soil erosion and deposition rates over the last 50 years.
- The technique permits soil loss and deposition quantification associated with sheet erosion which is difficult to assess using other classical approaches at a field scale.
- A laboratory gamma spectrometry facility is needed to analyze ¹³⁷Cs concentrations. However its concentration can also be assessed in the field through portable in situ gamma spectrometers with a significantly shorter counting time and less field disturbance. For example in order to obtain an acceptable in situ measurement in the Mistelbach watershed for an areal activity close to 1900 Bq m⁻² only 3600 s for ¹³⁷Cs measurement were needed instead of 10 000s count in the laboratory.

²¹⁰Pb (Lead-210)

- ²¹⁰Pb is a natural geogenic radioisotope ($t_{1/2} = 22.26$ years). The ²¹⁰Pb produced in the soil is termed 'supported' and the additional ²¹⁰Pb coming as fallout associated with rainfall is termed 'unsupported' or atmospherically derived ²¹⁰Pb or excess ²¹⁰Pb (²¹⁰Pb_{ex}). The amount of excess ²¹⁰Pb is obtained by subtracting the supported ²¹⁰Pb component in equilibrium with ²²⁶Ra from the ²¹⁰Pb total activity.
- The ²¹⁰Pb-method can be used in the Southern Hemisphere where the ¹³⁷Cs fallout is sometimes too low for precise determination.
- However, its measurement through low energy gamma spectrometry is not easy and requires trained staff. IAEA results from the Proficiency Test (PT) of the CRP D1.50.08 indicate that 80 % of the 14 laboratories involved were able to determine ¹³⁷Cs with accuracy whereas only 40 % obtained acceptable results for total ²¹⁰Pb.
- In some cases such as our experimental site in Mistelbach (Austria), where as a result of the similar activity of total ²¹⁰Pb and ²²⁶Ra coupled with the high variability of the initial fallout inventory, it is not possible to utilize the method of ²¹⁰Pb to assess soil erosion and sedimentation rates.

⁷Be (Beryllium-7)

- ⁷Be is a natural cosmogenic radionuclide produced in the upper atmosphere by cosmic ray spallation of nitrogen and oxygen.
- This radionuclide has a very short half life ($t_{1/2} = 53.3$ days) relative to ¹³⁷Cs and ²¹⁰Pb, which means that it offers potential for investigating soil erosion process occurring during shorter timescales.
- A highly skilled team is required if using ⁷Be methodology.
- The main limitation when using ⁷Be is the need to collect soil samples at shallow depths of 2 mm to 5 mm increments to establish the initial ⁷Be vertical distribution in the soil. This limitation has been addressed through the development of a Fine Soil Increment Collector (FSIC) which is also mentioned in the following article.

Development of a Fine Soil Increment Collector (FSIC) to solve the main limitation of the use of ⁷Be as a soil tracer

Lionel Mabit (Soil Science Unit), Arsenio Toloza (Soil Science Unit) and Anton Nirschl (Mechanical Workshop-Seibersdorf)

⁷Be methodology can be a very useful soil tracer in the implementation of short term erosion/sedimentation studies. However, the main limitation in the use of ⁷Be is the need to restrict soil sample collection to shallow depths due to its superficial deposit on the topsoil. To address this limitation, the Soil Science Unit in collaboration with the Seibersdorf mechanical workshop developed a new tool – the FSIC (Fine Soil Increment Collector; Figures 1 and 2)

This equipment has been successfully field tested at Seibersdorf and in Mistelbach, Austria.

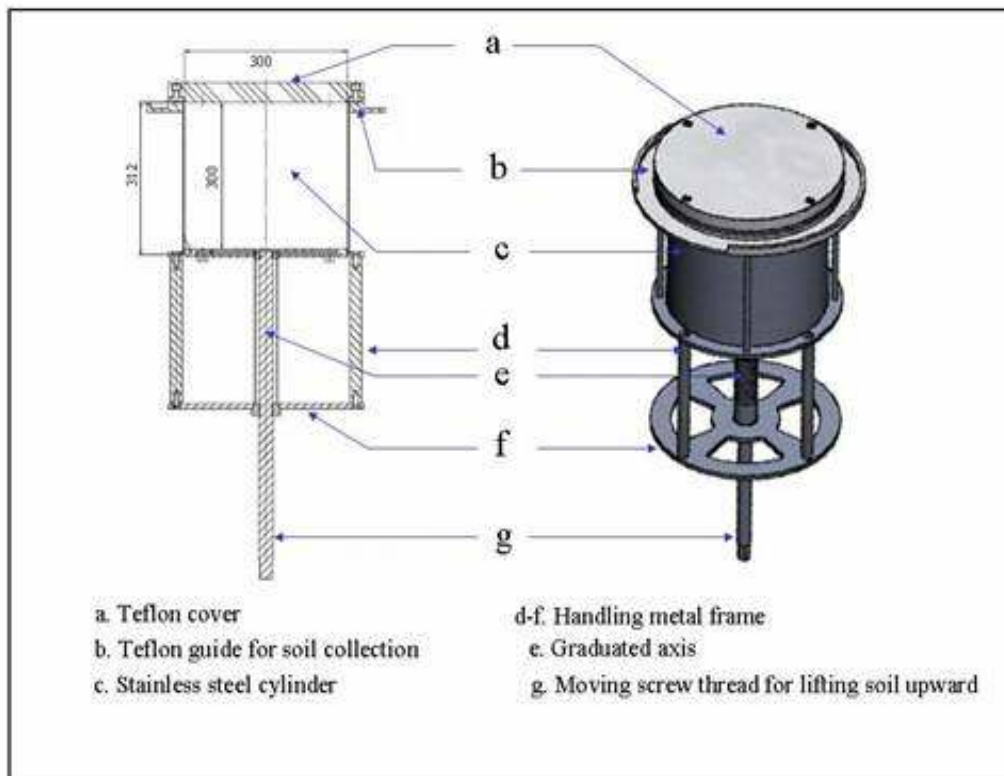

Figure 1. Technical description of the fine soil increment collector.

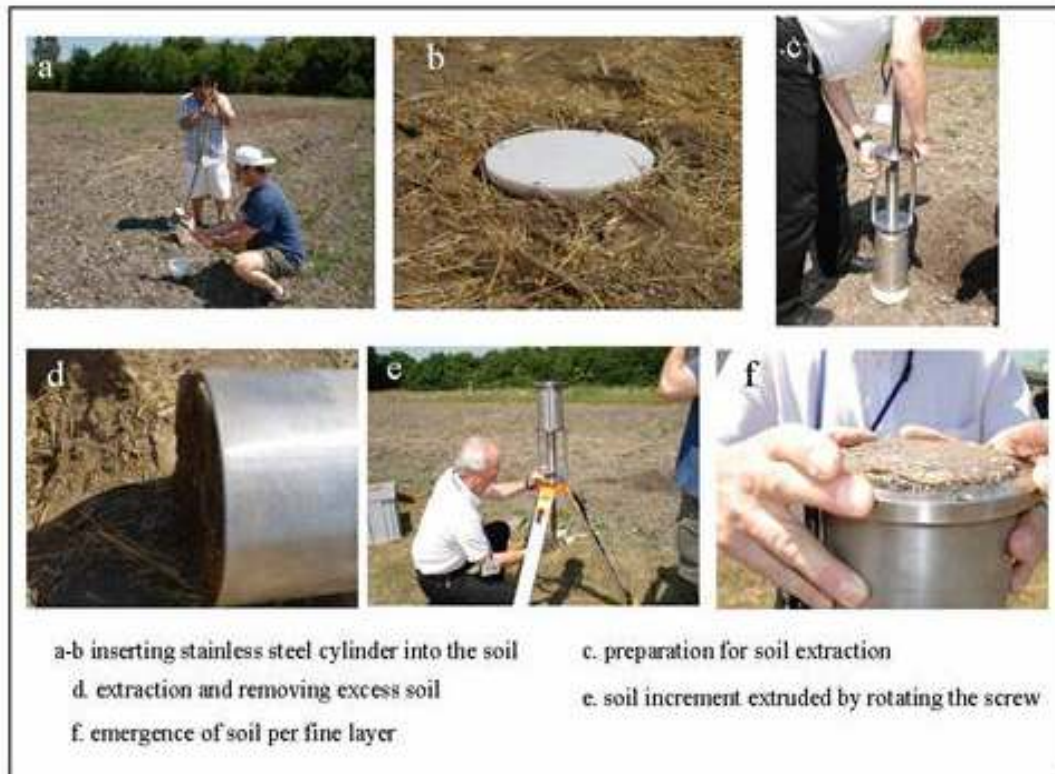

Figure 2. Test of the FSIC under field conditions in Seibersdorf and Mistelbach.

Fine-tuning Methodologies to Determine Phosphorus Fractions in Plant- and Soil Samples labelled with Radioisotope ^{32}P and/or ^{33}P

Martina Aigner and Joseph Adu-Gyamfi (SSU)

In preparation for the $^{32}\text{P}/^{33}\text{P}$ work in the laboratory and greenhouse, selected methods for the determination of P fractions in plant and soil were tested and fine-tuned with non-labelled materials. Selected materials were validated against certified reference materials (NIST1547, NIST 1646, NIST 2709) where available or compared to analytical results provided by national soil-testing laboratories on an internal standard soil and/or tested soil samples. The tested methods were applied to fractionate the low -P soil, which has been selected for future ^{32}P experiments in the newly refurbished greenhouse experiments.

The following methods have been identified and validated:

- *Total P in plant samples* by wet digestion with concentrated sulphuric acid
- *Total P in soil samples* by perchloric acid digestion
- *Available P in soil samples* by the Bray-P2 extraction method
- *Fractionated extraction* of Ca-P, Fe-P and Al-P in low P soils (pH 5.9) by acetic acid, ammonia fluoride and sodium hydroxide extractants, respectively.

The next step will be to use ^{32}P labelled plant and soil-samples for the tests.

A Rehabilitated Greenhouse for ^{32}P Radioisotope Studies and Training in Seibersdorf

Joseph Adu-Gyamfi (SSU)

Two major activities of the Soil Science Unit in Seibersdorf are to develop and test isotope methodologies and guidelines to support CRPs and TCPs, and to conduct training to strengthen the analytical and professional capabilities of Member States. This is achieved through regional, interregional and laboratory training.

Whereas development of methodologies and guidelines for stable isotopes such as (^{13}C , ^{15}N , ^{18}O) in the Unit has advanced in the area of soil-water-nutrient plant continuum, the use of isotopes of phosphorus (^{32}P , ^{33}P) has received little attention in the Unit during the last ten years. The main reason for this has been the lack of a greenhouse and laboratories, that conform to the required safety standards for conducting experiments because of the radioactive nature of the phosphorus isotopes. In most of the developing countries where P bio-availability in the soil is low, the use of ^{32}P and ^{33}P is crucial to understanding P dynamics in soil, and to quantify P pools that can be mobilized by crop genotypes with superior nutrient resource recovery.

In response to a demand from Member States to train fellows in the use of P isotopes, and the need to conduct research to support the on-going CRP on Selection and Evaluation of Food (Cereal and Legume) Crop Genotypes Tolerant to Low Nitrogen and Phosphorus Soils through the Use of Isotopic and Nuclear-related Techniques (D1.50.10), the Soil Science Unit has refurbished an old glasshouse (new ventilation and cooling systems, floor renovation etc) and a laboratory to a Type B radiation standard. Fellowship training in the use of ^{32}P and ^{33}P radio-isotopes for soil P dynamics and P nutrition experiments, safety precautions, sample preparation, measurements using a liquid scintillation counter and calculations, will now be conducted at the Soil Science Unit in Seibersdorf.

Training

Interregional training course on Use of Nuclear and Related Techniques to Measure Storage, Flows and Balance of Water in Cropping Systems, 1 to 25 October 2007

Course Director: Joseph Adu-Gyamfi

An interregional training course on the Use of Nuclear and Related Techniques to Measure Storage, Flows and Balance of Water in Cropping Systems was organized jointly by the SWMCN Section and the Soil Science Unit (SSU) and held from 1 to 25 October 2007 at the Agency's Laboratories, Seibersdorf.

The workshop was announced in March 2007 and 60 applications from 39 developing countries in five regions were received by 15 July 2007.

Region	Countries	Number of Applicants
Africa	17	29
Middle East	5	7
Asia and Pacific	7	12
Latin America and the Caribbean	6	8
Europe	4	4

The prospectus for the course including the purpose, justification and description was published in the Soils Newsletter Vol. 30, 1, July 2007.

Eighteen candidates from 18 countries were selected based on their qualifications, general experience, experience with water management, knowledge in the use of nuclear and related techniques, age and the benefits the respective countries might derive from their participation. Qualified candidates not selected were retained in the database of the SWMCN Section so that they may be informed of other training courses. In addition to the 18 candidates who received funding from FAO, four candidates were nominated and sponsored by the IAEA Department of Technical Cooperation (TC). The staff of the SWMCN subprogramme and four invited instructors (selected on the basis of their technical/research skills, technology dissemination capability and future networking) from USA, Israel and Austria, gave lectures and conducted practical work during the training course.

The workshop opened on 1 October 2007 in Seibersdorf with welcoming addresses by the Acting Director of the

Agency's Laboratories, the Acting Director of NAFA/AGE, the Acting Head of the FAO/IAEA Agriculture and Biotechnology Laboratory, and the Head, of the Soil Science Unit.

The keynote address was delivered by Mr. Werner Burkart, Deputy Director General (DDG), Department of Nuclear Sciences and Applications. The DDG stressed that although agriculture is the predominant user (75-80%) of fresh water resources, the competition among different sectors for water is increasing because of climate change resulting from global warming, increased demand for water from urban and industrial sectors and the increased awareness of water quality for recreational purposes and tourism. Mr. Burkart outlined the challenges and stressed that there is a need to increase on-farm water use efficiency, to produce more food with less water (i.e., to achieve more crops per drop) and to enhance water use efficiency and crop water productivity. He wished all the participants and instructors a very successful training course and an enjoyable stay in Vienna. During a keynote lecture on Integrated Land and Water Management for Food and Environmental Security, Mr. Winfried Blum, President, European Confederation of Soil Science Societies, acknowledged the goods and services provided by land and soil and the need to strike a balance between productivity and efficiency of land use. Large scale production of crops for bio-fuel, and its consequences on the land productivity was highlighted. A welcome cocktail hour concluded the day's proceedings.



Mr. W. Burkart, DDG-NA, addressing the participants

In the first week of the Course participants learned about new developments in soil water monitoring devices and took part in computer laboratory exercises aimed at estimating crop water use. The participants were taught the principles behind the electromagnetic (capacitance) probes and why they do not work effectively. During practical sessions they learned how to use the hydroprobes in the field and also learned how to build their own time domain reflectometry (TDRs). It was emphasized that the soil moisture readings from the neutron probe are currently the best, but the need for better capacitance sensors was advocated.

Lectures and practicals during the second week focused on plant water relationships, evapotranspiration and crop water use and requirements. Participants learned about the theory and construction of thermocouples and TDR sap flow sensors and constructed their own thermocouples and TDR sap flow sensors to measure and analyze sap flow in citrus. The use of porometers to measure transpiration and leaf conductance and portable infra red (IR) thermometers for measuring the crop water stress index was also demonstrated.

As a follow up to the lectures in the second week, the third week lectures and practical sessions in the third week focused on an introductory lecture which outlined the use of stable isotopes to trace plant source water, leaf water isotope enrichment and transpiration and combining ^{13}C and ^{18}O to understand plant response to a water deficit. Participants had field practicals on isotopic procedures for determining sources and fluxes of water in plants and soil, and isotopic methods for integrating inputs and losses to receiving water bodies. There was also a computer laboratory exercise on interpreting, understanding and presenting data generated from the Mass Spectrometer.

The last week of the course was devoted to practical field training both in Seibersdorf and at the BOKU University

in Großenzersdorf. Participants also prepared individual proposals for presentation outlining the applicability of the proposed project to their individual developing countries.



Field training for participants



Participants in the Laboratory

Fellowships

Name	Country	Area of Training	Period
Mr. David A Kamara (SIL/05007)	Sierra Leone	Use of ^{15}N isotope dilution methodology to quantify biological nitrogen fixation in grain legumes	16 Apr to 15 Oct
Ms. Martina Sturm (SLO/07004)	Slovenia	Crop production practices on soil water balance and nitrate movement within and beyond the crop root zone. Attendance of the Interregional Training Course.	16 Apr to 15 Oct
Mr. Peter Korpar (SLO07005)	Slovenia	Field practical training on the application of soil water monitoring equipments and the application of stable isotopes in water management. Attendance of the Interregional Training Course.	15 Sep to 14 Dec
Mr. John H. KIHUMBA (KEN06005)	Kenya	Attendance of the Interregional Training Course	1 to 30 Oct
Mr. Leonard BUCKLE (SIL07002)	Sierra Leone	Attendance of the Interregional Training Course	7 Oct to 6 Nov

Scientific Visits

Name	Country	Area of Training	Period
Mr. David A Kamara (SIL/05007)	Sierra Leone	Use of ^{15}N isotope dilution methodology to quantify biological nitrogen fixation in grain legumes	16 Apr to 15 Oct

Visitors

Mr. Eric McGaw, Communications Specialist, International Center for Biosaline Agriculture, Dubai, United Arab Emirates visited the SWMCN Section on 4 September 2007 to discuss possible collaboration on the use of nuclear techniques in biosaline agriculture.



Mr. Nguyen with Mr. Eric McGaw

Analytical services

The Soil Science Unit continues to provide stable isotope analyses for CRPs, TCPs and for other FAO/IAEA regular activities. The following table summarizes the analytical services provided during the period January to July 2007.

		CRP	TC	Seib	Contract	Total
Samples received		819	131	950	0	1 900
Requested analyses	¹⁵ N enriched	91	131	810	0	1 032
	¹⁵ N nat. ab.	0	0	126	0	126
	¹³ C nat. ab.	728	0	841	0	1 569
	Total	819	131	1 777	0	2 727
Measurements carried out	¹⁵ N enriched	142	212	1 186	113	1 653
	¹⁵ N nat. ab.	53	542	268	0	863
	¹³ C nat. ab.	1 355	0	1 782	0	3 137
	Total	1 550	754	3 236	113	5 653

Annual Proficiency Test (PT) IAEA-SSU-2007-01 on ¹⁵N and total N as well as ¹³C and total C in plant materials

Twenty eight institutes expressed their interest in the new round of PTs. 14 labs applied for the combined ¹⁵N/total N-analysis and 14 labs wanted to participate in both, the ¹³C/total C and the ¹⁵N/total N analysis. The test materials were prepared for homogeneity testing and reference value assignment. Due to an instrumental breakdown (the elemental analyzer coupled to the IRMS), the test materials still could not be characterized and sent out. The PT is therefore postponed until further notice.

Publications

Recent Titles

Dercon, G., Govers, G., Poesen, J., Rombaut, K., Vandenbroeck, E., Sánchez, H., Loaiza, G., Deckers, J., (2007). Animal-powered tillage erosion assessment in the Southern Andes region of Ecuador. *Geomorphology*, 87, 4-15.

Mabit, L. (2007). Use of Geostatistics to Establish Soil Movement Map and Sediment Budget Using Fallout Radionuclides (FRN). In: Proceedings of the tenth International symposium on river sedimentation. Effects of river sediments and channel processes on social, economic and environmental safety. 10th International Symposium on River Sedimentation, 1-4 August 2007, Moscow, Russia. Publication of the Moscow University, Russia. Vol I. pp.247–254.

Mabit, L. and Bernard, C. (2007). Assessment of spatial distribution of fallout radionuclides through geostatistics concept. *Journal of Environmental Radioactivity*, 97(2-3): 206–219.

Mabit L., Bernard C. and Laverdière M.R. (2007). Assessment of erosion in the Boyer River watershed (Canada) using a GIS oriented sampling strategy and ^{137}Cs measurements. *Catena*, 71(2): 242–249.

Mabit, L., Bernard, C. and Laverdière, M.R. (2007). Water erosion measurement at the watershed level by the Cs^{137} method. (Étude de la dégradation des sols par l'érosion hydrique à l'échelle des bassins versants en utilisant la méthode du Cs^{137}). *Agrosolution*, 18, 1, 12–16.

Nguyen, M.L., Heng, L.K.; Zapata, F. The Use of Nuclear and Isotopic Techniques in Improving Water Productivity in Agriculture: Food Security and Environmental Sustainability. In UNIDO Technology Foresight Summit Water Productivity in Industry. 2007e-Poster, 27-29 September 2007, Budapest, Hungary.

Pathak, H., Yadvinder-Singh, Hussain, A., Hussain, F., Munnankarni, R.; Gathala M., Nguyen, M. L., Ladha, J.K. 2007. Use of CERES Model for Evaluation of Resource Conservation Technologies in Rice-Wheat System in South Asia. The 2007 International Annual Meeting of the American Society of Agronomy (ASA), Crop Science Society of America (CSSA) and Soil Science Society of America (SSSA), 4-8 November 2007, New Orleans, Louisiana, USA.

Pansak, W., Dercon, G., Hilger, T. H., Kongkaew T. and Cadisch, G., 2007. ^{13}C isotopic discrimination: A starting point for new insights in competition for nitrogen and water under contour hedgerow systems in tropical mountainous regions. *Plant and Soil*. 298, 175-189.

Pansak, W., Hilger, T. H., Dercon, G., Kongkaew T. and Cadisch, G., 2007. Mineralisation and leaching of nitrogen as affected by contour hedgerow systems on moderate slope in Northeast Thailand. *In* Utilisation of diversity in land use system: Sustainable and organic approaches to meet human needs, International research on food security, natural resource management and rural development, Tropentag 2007 Witzhausen, 9-11 October 2007, Eds. Tielkes, E., pp. 400.

Zaman, M., Nguyen, M.L., Matheson, F., Blennerhassett, J.D., Quin, B.F., 2007. Can soil amendments (zeolite or lime) shift the balance between nitrous oxide and dinitrogen emissions from pasture and wetland soils receiving urine or urea-N. *Australian Journal of Soil Research* 45: 543-553.

Websites

- Soil and Water Management and Crop Nutrition Section:
<http://www-naweb.iaea.org/nafa/swmn/index.html>
- Joint FAO/IAEA Division of Nuclear Techniques in Food and Agriculture:
<http://www-naweb.iaea.org/nafa/index.html>
- FAO website: <http://www.fao.org/waicent/FAOINFO/AGRICULT/Default.htm>
- FAO/AGL (Land and Water Development Division):
<http://www.fao.org/ag/agl/default.stm>



IAEA
International Atomic Energy Agency

Soils Newsletter
Vol. 30, No. 2

January 2008

The Soils Newsletter is prepared twice per year by the Soil and Water Management & Crop Nutrition Section, Joint FAO/IAEA Division of Nuclear Techniques in Food and Agriculture and FAO/IAEA Agriculture and Biotechnology Laboratory, Seibersdorf.

International Atomic Energy Agency
Wagramer Strasse 5, P.O. Box 100,
A-1400 Wien, Austria

Printed by the IAEA in Austria,
January 2008

08-01461