

G. Logan, F. Bieniosek, C. Celata, E. Henestroza, J. Kwan, E. P. Lee, M. Leitner, L. Prost, P. Roy, P.A. Seidl, S. Eylon, J-L. Vay, W. Waldron, S. Yu

Lawrence Berkeley National Laboratory, Berkeley, CA 94720, USA

J. Barnard, D. Callahan, R. Cohen, A. Friedman, D. Grote, M. Kireeff Covo, W. R. Meier, A. Molvik, S. Lund

Lawrence Livermore National Laboratory, Livermore, CA, USA

R. Davidson, P. Efthimion, E. Gilson, L. Grisham, I. Kaganovich, H. Qin, E. Startsev, Princeton Plasma Physics Laboratory, Princeton, NJ 08543, USA

D. Rose, D. Welch, Mission Research Corporation, Albuquerque, NM, USA

C. Olson, Sandia National Laboratories, USA

R. Kishek, P. O'Shea, I. Haber, University of Maryland, College Park, MD, USA

### Abstract

Significant experimental and theoretical progress has been made in the U.S. heavy ion fusion program on high-current sources, injectors, transport, final focusing, chambers and targets for high energy density physics (HEDP) and inertial fusion energy (IFE) driven by induction linac accelerators. One focus of present research is the beam physics associated with quadrupole focusing of intense, space-charge dominated heavy-ion beams, including gas and electron cloud effects at high currents, and the study of long-distance-propagation effects such as emittance growth due to field errors in scaled experiments. A second area of emphasis in present research is the introduction of background plasma to neutralize the space charge of intense heavy ion beams and assist in focusing the beams to a small spot size. In the near future, research will continue in the above areas, and a new area of emphasis will be to explore the physics of neutralized beam compression and focusing to high intensities required to heat targets to high energy density conditions as well as for inertial fusion energy.

### I. Introduction

A coordinated beam physics program by the Lawrence Berkeley National Laboratory, Lawrence Livermore National Laboratory, and Princeton Plasma Physics Laboratory (the Heavy-Ion Fusion Virtual National Laboratory), together with collaborators at Mission Research Corporation, Sandia National Laboratories, and the University of Maryland, pursues intense space-charge-dominated beam science in support of applications of heavy-ion beams to high energy density physics and to inertial fusion energy. A unifying research theme for the US program is to address a key scientific question of fundamental importance to both high energy density physics and inertial fusion energy- *“How can heavy ion beams be compressed to the high intensities required for creating high energy density matter and fusion ignition conditions”*. The primary scientific challenge is to compress intense ion beams in time and space sufficiently to heat targets to the desired temperatures with pulse durations of order or less than the target hydrodynamic expansion time. Present experiments, theory and simulations investigate key technical issues that can affect the brightness (focusability) of space-charge dominated beams, including the effects of gas and electron cloud interactions, as well as emittance growth during focusing of such intense beams, including the effects of neutralizing background plasma. Section II describes selected highlights of recent research since the 2002 IAEA Fusion Energy Conference. In particular, recent particle-in-cell simulations of planned near-term experiments of modest scale indicate that intense heavy ion beams injected with an appropriate head-to-tail

velocity gradient (“tilt”) into a long neutralizing background plasma column may be compressed by more than a factor of 100 in length and focused by a factor greater than 20 in radius (> 40,000 increase in intensity). Section III describes newly developed research plans for the next several years on neutralized beam compression and focusing.

## II. Recent research progress

**Source Test Stand (STS):** Progress has been made both in the generation of high brightness beamlets for the compact driver-scale injector concept using merging beamlets, as well in the study of beam optics using large surface ionization sources. High brightness beamlets of  $\text{Ar}^{+1}$  ions have been measured with current density ( $100 \text{ mA/cm}^2$  @ 5 mA), emittance ( $T_{\text{eff}} < 2 \text{ eV}$ ), charge-state purity (> 90% in  $\text{Ar}^{+1}$ ), and energy spread (< 0.01%) supporting future merging-beamlet injectors for heavy ion fusion [1]. Sixty-one beamlets have been extracted through 4 Einzel lens arrays supported by multi-layer, high-gradient insulators (Figure 1) with 20 % beamlet current uniformity across the array. Experiments planned during the next year [1] will test simulations [2] of emittance growth in the transverse merging of arrays of about 100 beamlets for compact, high total current injectors. Another experiment was set up on a 500-kV test stand to study the beam optics of an extraction diode using a 10-cm diameter aluminosilicate source [1]. In comparing the experimental results with WARP-3D computer simulations, we found excellent agreement in the emittance diagram (Figure 2) and also in the beam current rise time.

**High Current Experiment (HCX):** Transport of a very high brightness ( $0.4 \leq \epsilon_n < 0.5 \text{ mm-mrad}$ ), 0.18 A, 1 MeV  $\text{K}^+$  beam shows no emittance growth through five lattice periods of electrostatic quadrupoles (Figure 3). Beam loss has been reduced  $\sim 3 \times$  due to improved injector voltage waveform control, and improved envelope control [3, 4]. Envelope simulations for these experiments accurately predict envelope evolution to within measurements uncertainties. In these results (see phase space measurement inset in Fig. 3), the beam fills 80% of the physical aperture, an encouraging result for the economic viability of HIF. However, longer lattice experiments are needed to confidently extrapolate to the driver scenario. We have developed conceptual designs and simulations [5] of a complete “source-to-target” experiment, the Integrated beam Experiment (IBX) that would allow the integrated scientific study of the evolution of a high current single heavy ion beam through all sections of a possible heavy ion fusion accelerator: the injection, acceleration, compression, and beam focusing. We have also developed and successfully tested prototype superconducting magnets for such a facility [6]. Experiments involving transport through four pulsed quadrupole magnets (Fig. 3) began in May 2003, especially to study gas and electron effects [7]. Simulations using both envelope and discrete-particle WARP models are guiding the experiments, which require matching into a magnetic quadrupole lattice that has a half-period significantly different from that of the upstream electrostatic transport line [2]. Work in progress includes use of electron clearing electrodes, a variety of new diagnostics, in particular, use of optical imaging of the whole beam cross-section using fast scintillators [8], and simulations [9].

**Neutralized Transport Experiment (NTX):** A very high brightness ion beam ( $\epsilon_n < 0.05 \text{ } \pi\text{mm-mr}$  at 25 mA, 300 keV  $\text{K}^+$ ), together with neutralization of beam space charge with preformed plasmas, produces small neutralized beam focal spots in the Neutralized Transport Experiment [10]. A MEVVA (“plug”) plasma source (used just beyond the last focusing magnet) and an RF (“volume”) plasma source located near the focal plane have been characterized. Figure 4 shows the beam focal spot sizes for three cases of space charge neutralization: a large focal spot of

several cm without any preformed plasma (left panel), a spot size reduced by almost a factor of 10 with a localized “plug” plasma just beyond the last focusing magnet (center panel) and a further 25% reduction in FWHM of spot size is seen (right panel) when both “plug” and “volume” plasmas are used. Particle-in-cell calculations using the hybrid LSP code [11] predicts an rms spot radius of 1.4 mm for the case of a plug plasma (center panel), in good agreement with the experiment.

***Scaled long-path experiments:*** Long-path-transport physics experiments have begun with the University of Maryland Electron Ring [12], and with the Paul Trap Simulator Experiment at PPPL [13]. These novel experiments allow the study of relevant driver beam dynamics over 100’s to 1000’s of lattice periods at modest cost.

***Theory and simulation:*** The increased need to study gas and electron cloud effects, and to study beam-plasma interactions in the drift compression and final focus regions of neutralized beams has motivated much progress in advancing heavy ion fusion beam transport models and simulation codes to include multi-species effects and beam-plasma instabilities. Noteworthy are studies [14, 15] of two-stream instabilities caused by background electrons, of interest both to heavy ion fusion and intense proton storage rings. The effects of electron clouds on beam loss have been studied by including electron cloud models in WARP simulations [9]. New mesh refinement capabilities in WARP [16] and other improvements [2] have enabled very good agreement between injector simulations and measurements, including accurate time dependent rise of the current. Simulations of collective relaxation processes have shown that surprising degrees of space-charge nonuniformity are tolerable. Integrated 3-D simulations of an integrated beam experiment have shown development of a clean beam “tail” and quiescent beam propagation. Simulations of temperature anisotropy modes [17] have recently been extended to 3-D. Studies [18] of non-neutral drift compression have been carried out, examining the dependence of emittance growth and sensitivity to errors upon the major beam and lattice parameters.

***IFE chamber and target research:*** New heavy ion target designs (“hybrid-distributed radiator”) have been developed that would allow much larger (5mm radius) focal spots, and experiments to test symmetry features in such targets are underway on the Sandia National Laboratories Z-facility [19]. Processes have been identified to mass manufacture heavy ion hohlraum targets at low cost and to inject them at 5 Hz [20]. A new technique of periodic vorticity injection and ejection allows a new class of thick-liquid-protected large-vortex inertial fusion energy chambers to be designed with flexible ranges of internal cavity shapes. A study of a multiple-beam induction-linac-driven power plant study [21] shows that detailed requirements for distributed radiator targets (spot size, power, symmetry and pulse shape) can be met by neutralized ballistic focusing of a 120 beam array over 6-meter focal lengths. A recent study shows that smaller focal spots may be obtained using negative ion beams. Provided neutralized drift compression and focusing and larger-spot hybrid targets can be experimentally validated, recent preliminary studies indicate modular induction linac driver systems with about 20-40 linacs may be cost-competitive.

### **III. Research plans for neutralized drift compression and focusing**

After acceleration, longitudinal drift compression by a factor of ten or more, followed by focusing onto a target, has always been an essential step for any approach to heavy ion fusion. For less than a few hundred beams, longitudinal and radial confinement of ion beams undergoing either RF or induction acceleration is manageable only for pulse lengths long compared to the 10

ns requirement of the target. In the 1970's and 80's, concerns about beam plasma instabilities motivated seeking "vacuum" solutions to heavy ion fusion that did not require plasma neutralization anywhere except in the target. However, vacuum solutions require high kinetic energies, of order 10 GeV, and many beams, likely a 100 or more. Since 1995, the US program has studied neutralization of converging beams with preformed plasmas after final focus to reduce projected driver voltage (2-4 GeV) to reduce cost. Both experiments and simulations have since shown that beam-plasma interactions after final focus can be beneficial overall (focal spot size reduced despite increases in beam emittance during neutralization), and that instabilities can be suppressed if the background plasma density is sufficiently large compared to the beam density.

Several recent factors motivate US research to consider neutralization of heavy-ion beams with preformed plasma not only in the target chamber, but also in the drift compression region between the accelerator and the target chamber. First, recent theory and simulations suggest that there are several ways to focus the beams after longitudinal compression within background plasma, even with the coherent head-to-tail velocity tilt remaining from the drift compression in plasma. Beam-plasma instability studies for neutralized drift compression indicate instabilities in regimes with sufficient plasma  $n_p \gg n_b$  and within embedded solenoid fields, may not strongly impair the final focus. Figure 5 shows an illustrative simulation of a possible neutralized drift compression and focusing experiment using reconfigured NTX equipment that shows  $> 100 \times$  axial compression with  $> 20 \times$  radial focusing to  $> 40000 \times$  increase in beam intensity. A series of three experiments with increasing beam compression and intensity on targets are envisioned. Second, the US government has requested increased emphasis on near-term applications of heavy-ion beams to high energy density physics studies, for which targets require very short pulses. A planned goal is to show the feasibility of an approach to isochoric target heating to  $> 1$  eV with MeV-class heavy ion beams within five years. Recent work [22] has shown that the target heating with ions just above the Bragg peak in  $dE/dx$  can be very uniform, but the high perveance of such beams for warm dense matter studies at 1 to 10 eV would require neutralized drift compression and focusing. Finally, studies indicate that a system of about 20 modular, solenoid focused induction linacs with neutralized drift compression and focusing, should be able to meet the 5 mm focal spot requirements for hybrid heavy ion targets, could be cost competitive, and would offer an attractive development path to inertial fusion energy. In fact, neutralized drift compression and focusing may also reduce the linac voltage, length and cost for multiple-beam quadrupole linac drivers as well.

Scientific issues for neutralized drift compression and focusing (key areas for further research) include:

- (a) Injection/acceleration/bunching to required high perveance ( $> 10^{-2}$ ) and with sufficiently low parallel and transverse emittances before plasma neutralization to allow the desired large beam compressions in plasma.
- (b) Beam transitions at high line-charge densities from Brillouin flow into neutralizing plasma columns with tolerable emittance increases while preventing electron back-flow.
- (c) Control of beam plasma instabilities over long regions of drift compression in background plasma, and controlled stripping, which do not interfere with final focusing to required target sizes.

- (d) Extension of neutral final focus to longer standoff distances with uncompensated velocity tilts, sufficient to meet either neutralized ballistic focus or assisted-pinch transport radii.
- (e) Validation of symmetry control in large-focal-spot hybrid targets for IFE [22].

#### IV. Conclusions

The present and planned research are intended to provide the physics knowledge base needed to optimize the design of future heavy ion accelerators such as the Integrated Beam Experiment (IBX), new facilities designed to drive high energy density physics targets with ions just above the Bragg peak in  $dE/dx$ , and drivers, including multiple-beam quadrupole-focused linac and modular, separate solenoid-focused linac development path options to inertial fusion energy.

\*This work was performed under the auspices of the U.S. Department of Energy by the University of California, Lawrence Berkeley and Lawrence Livermore National Laboratories under Contract Numbers DE-AC03-76SF00098 and W-7405-Eng-48, and by the Princeton Plasma Physics Laboratory under Contract Number DE-AC02-76CH03073.

#### References

- [1] J. Kwan, Rev. Sci. Instr. Vol. 75, No. 5, pg 1838 May 2004.
- [2] D. Grote, et. al., Phys. Rev. ST Accel. Beams **6**, 014202 (2003).
- [3] P. Seidl, et. al., *Proc. of 2003 Part. Accel. Conf., Portland, USA 2003*, edited by J. Chew, et al., (IEEE # 03CH37423C), p. 536. . See also supporting beam simulations by A. Friedman, et. al. *ibid*, p. 275, and by C. Celata, et. al. *ibid*, p. 1518.
- [4] L. Prost, "Experimental Study of the Transport Limits of Intense Heavy Ion Beams in the High Current Transport Experiment", submitted to Nuc Instr & Method A, 2004
- [5] M. A. Leitner et al., *Proc. of 2003 Part. Accel. Conf., Portland, USA 2003*, (IEEE # 03CH37423C), p. 1521.
- [6] G. Sabbi, *Proc. of 2003 Part. Accel. Conf., Portland, USA 2003* (IEEE # 03CH37423C) (2003), HIFAN 1269, LBNL-53463.
- [7] A. Molvik, "Experimental Studies of Electrons in a Heavy-Ion Beam", submitted to Nuc Instr & Method A, 2004
- [8] F. Bieniosek, et.al. , "Diagnostics for Intense Heavy Ion Beams", submitted to Nuc Instr & Method A, 2004
- [9] R. Cohen, Invited talk to be presented at American Physical Society DPP, November 2004
- [10] P. Roy, et. al, Physics of Plasmas, **11**, 2890, 2004. See also E. Henestroza et al., "Design and Characterization of a Neutralized-Transport Experiment for Heavy-Ion Fusion," accepted for publication on Phys. Rev. Special Topics - Accelerators and Beams, HIFAN 1276, LBNL-53928. (2003).
- [11] C. Thoma, D.R. Welch, S.S. Yu, P.K. Roy, S. Eylon, and E.P. Gilson, "Comparison of Experimental Data and 3D Simulations of Ion Beam Neutralization from the Neutralized Transport Experiment", submitted to Physics of Plasmas, September 2004.
- [12] R. Kishek, "HIF Research on the University of Maryland Electron Ring" submitted to Nuc Instr & Method A, 2004
- [13] E. P. Gilson, R.C. Davidson, P. Efthimion and R. Majeski, Phys. Rev. Lett. **92**, 155002 (2004).
- [14] R. Davidson, et.al., "Survey of Collective Instabilities and Beam-Plasma Interactions in Intense Heavy Ion Beams" (submitted to Physical Review-Special Topics on Accelerators and Beams).
- [15] H. Qin, E. A. Startsev and R. C. Davidson, Phys. Rev. Special Topics on Accelerators and Beams **6**, 014401 (2003). See also H. Qin, Physics of Plasmas **10**, 2708 (2003).
- [16] J.-L. Vay, et.al. "Application of Adaptive Mesh Refinement to PIC Simulations in Inertial Fusion", submitted to Nuc Instr & Method A, 2004
- [17] E. Startsev, et. al., Physical Review Special Topics on Accelerators and Beams **6**, 084401 (2003).
- [18] H. Qin, et.al., "Study of Drift Compression for Intense Heavy Ion Fusion Beams", submitted for publication (2003).

- [19] D. Callahan, et.al. "Heavy Ion Target Physics and Design in the USA", submitted to Nuc Instr & Method A, 2004
- [20] D. Goodin, et.al, "Progress in Heavy Ion Driven Target Fabrication and Injection" submitted to Nuc Instr & Method A, 2004
- [21] S. Yu, et.al., Fusion Science and Technology, 44, 266 (2003).
- [22] L. Grisham, "Moderate Energy Ions for High Energy Density Physics Experiments", Physics of Plasmas, in press (2004).

**Figures**

**Argon RF Source**

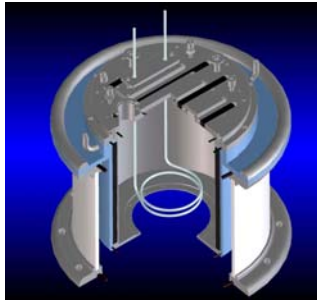

**Multiple beamlet-Einzel lens array w/high gradient insulators**

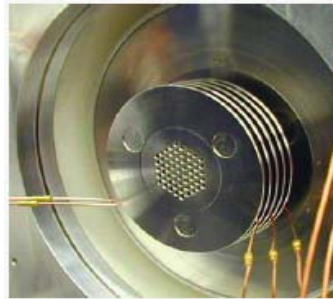

**Beamlet images on Kapton**

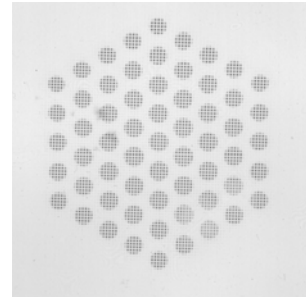

Figure 1: Source Test Stand (STS-100): Sixty-one beamlets have been extracted from an RF-argon plasma source, through a grid supported by three multi-layer high gradient insulator stacks (not visible), with brightness and uniformity meeting requirements for heavy ion fusion.

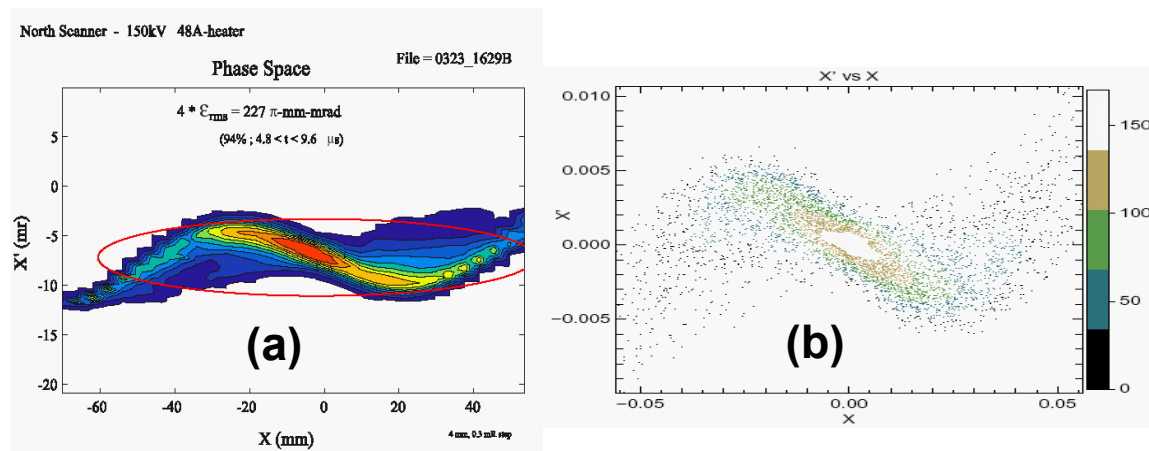

Figure 2 (a) Experimental phase space measured for an unapertured beam created with a 10-cm diameter alumino-silicate surface ionization source. (b) Warp-3-D particle-in-cell simulation of the experiment depicted in (a).

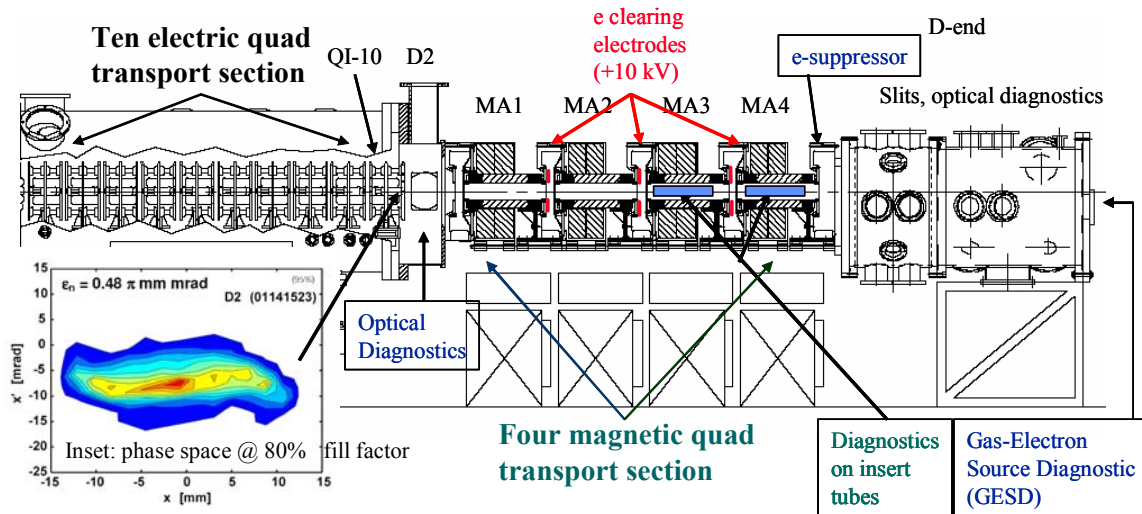

Figure 3: The High Current Experiment (HCX), showing the 5-lattice period electrostatic transport section and the new four magnetic quadrupole transport section and diagnostic locations where gas and electron cloud experiments are conducted. The inset shows a horizontal phase-space diagram following the HCX electrostatic transport section where the beam filled 80% of the aperture (maximum excursion of the beam envelope). The coherent envelope expansion of the beam has been removed so that any phase-space distortions are clearly visible. The mismatch amplitude in the upstream transport channel was  $1 \pm 0.5$  mm.

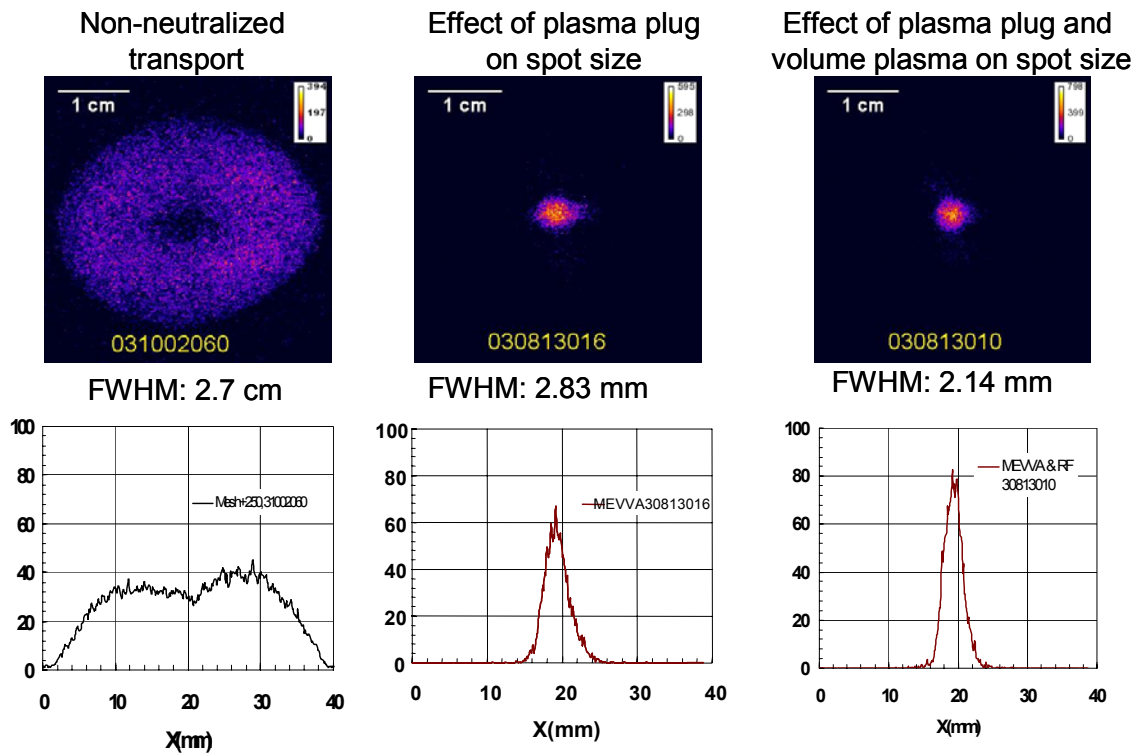

Figure 4. The Neutralized Transport Experiment (NTX) showing beam images at the focal plane for three cases of space-charge neutralization for a high perveance ( $6 \times 10^{-4}$ ), 25 mA, 300 keV  $K^+$

ion beam: left: no preformed plasma; center: localized “plug” plasma just beyond the last focusing magnet, and right: with both “plug” and “volume” preformed plasma.

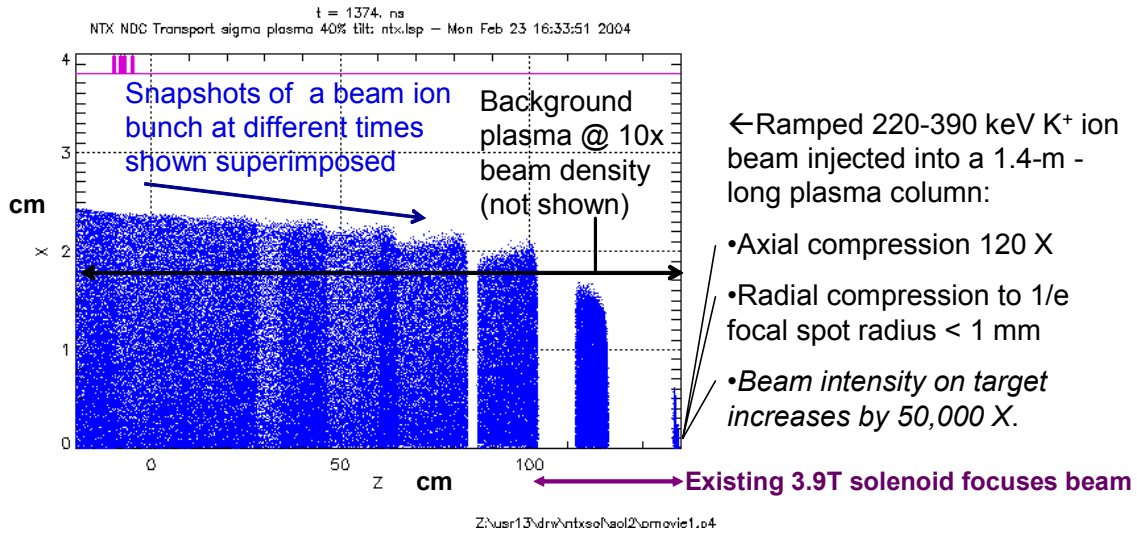

Figure 5: Particle-in-cell simulation of a possible experiment using NTX equipment to study longitudinal compression and radial focusing of an intense heavy ion beam within a neutralizing background plasma column. The peak beam current density exceeds 100 A/cm<sup>2</sup> on axis.