

International Atomic Energy Agency

**Opportunities, Challenges and Strategies for
Innovative SMRs Incorporating Non-electrical
Applications**

**Presentation by Vladimir KUZNETSOV
(IAEA)**

CONTENT

1. Introduction
2. IAEA project “Common Technologies and Issues for SMRs”
3. Market opportunities for innovative SMRs
4. Deployment potential of innovative SMRs
5. Design strategies for SMRs
6. Deployment strategies for SMRs
7. Competitiveness considerations
8. An approach to incorporate increased proliferation resistance
9. Common challenges for innovative SMRs
10. Conclusion

Introduction

Small Reactor: 0 – 300 MW(e)

Medium Sized Reactor: 300 – 700 MW(e)

In 2006:

- **Of 442 NPPs, 139** were with small and medium sized reactors (**SMRs**)
- **SMRs : 61.6 GW(e) or 16.7%** of the world electricity production
- **Of 31 newly constructed NPPs, 11** were with **SMRs**
- **More than 50 concepts and designs of innovative SMRs were developed in Argentina, Brazil, Canada, China, Croatia, France, India, Indonesia, Italy, Japan, the Republic of Korea, Lithuania, Morocco, Russian Federation, South Africa, Turkey, USA, and Vietnam**
- **Most of innovative SMRs provide for or do not exclude *non-electric applications***

IAEA project “Common Technologies and Issues for SMRs”

Objective:

- To facilitate development of the key enabling technologies and resolution of the enabling infrastructure issues common to innovative SMRs of various types

Participation:

- Argentina, Brazil, China, Croatia, France, India, Indonesia, Italy, Japan, the Republic of Korea, Lithuania, Morocco, Russian Federation, South Africa, USA, Vietnam; *Observers: European Commission, NEA-OECD*

Deliverables 2005-2007:

- ✓ TECDOC-1451 (May 2005) “Innovative SMRs: Design Features, Safety Approaches, and R&D Trends”
- ✓ TECDOC-1487 (Feb. 2006) “Advanced Nuclear Plant Design Options to Cope with External Events”

Status Reports:

- ✓ TECDOC-1485 (Mar. 2006) “Status of Innovative SMR Designs 2005: Reactors with Conventional Refuelling Schemes”
- ✓ TECDOC-1536 (Jan. 2007) “Status of Small Reactor Designs without On-Site Refuelling”

Market Opportunities for Innovative SMRs

- **The progress of innovative SMRs is defined by their capability to address the needs of those users that for whatever reason cannot benefit from economy-of-scale NPP deployments**
- ***Countries with small and medium electricity grids/ or limited energy demand growth/ or limited investment capability***
- ***Villages, towns and energy intensive industrial sites in off-grid locations***
- ***In the future, utilities and merchant¹ plants for non-electric energy services***

¹ Operating outside the regulatory framework of regulated utilities and selling their product on a competitive market

Deployment Potential of Innovative SMRs

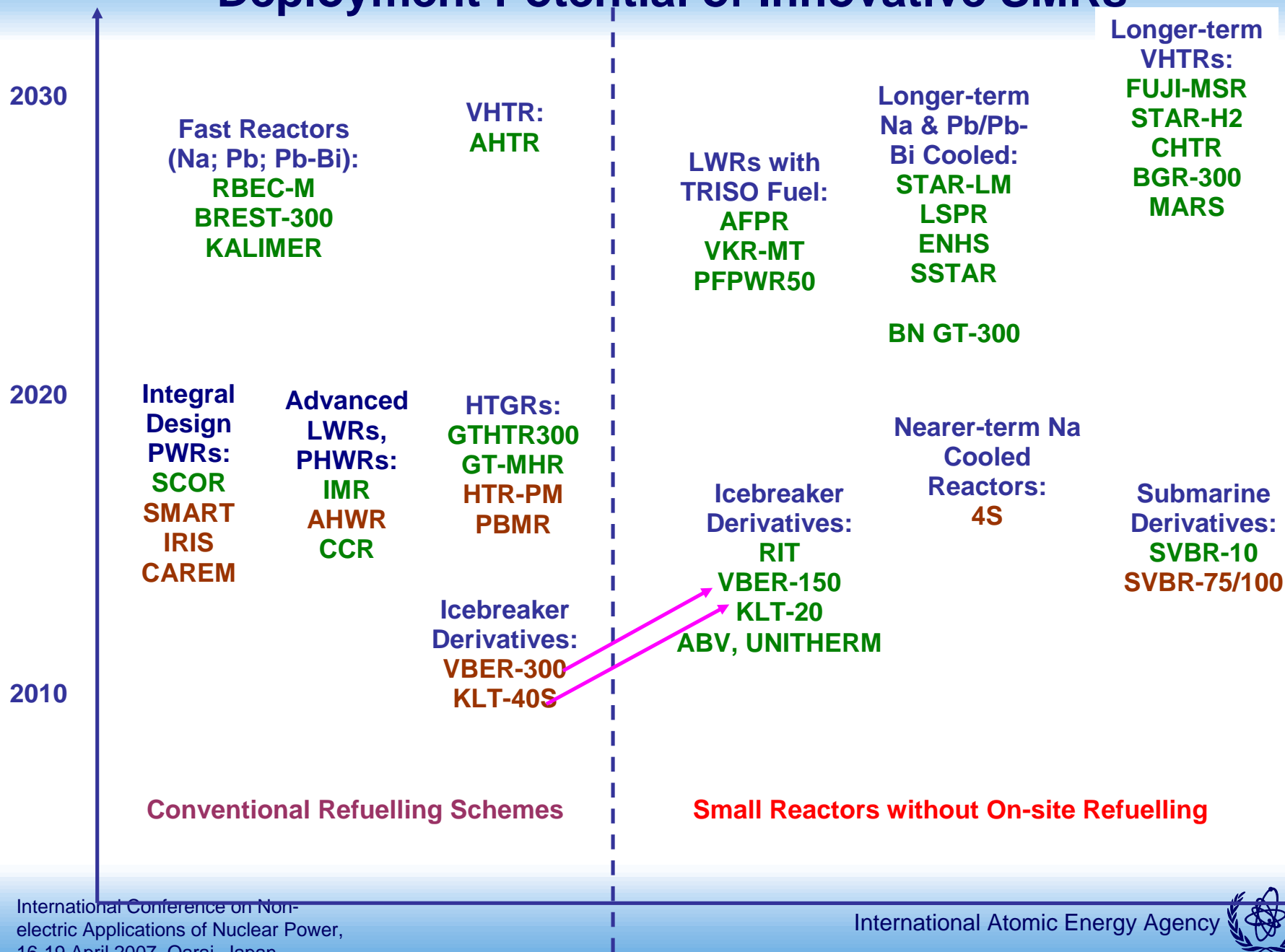

Design Strategies for innovative SMRs (1)

A potentially “Win-Win” strategy regarding plant safety and economy

- *To eliminate/prevent as much accident initiators/consequences as possible by design*
- *Then deal with the remaining part by appropriate combinations of active and passive systems*

Approach:

- *Realize design solutions that are optimum for the reactor of a given type and a given unit power*

Objectives:

- *High safety level for a variety of siting conditions and applications*
- *Greater plant simplicity and robustness with respect to human errors*
- *Improved economics*

Design Strategies for innovative SMRs (2)

Operational complexity of the plant could be quantified (1)

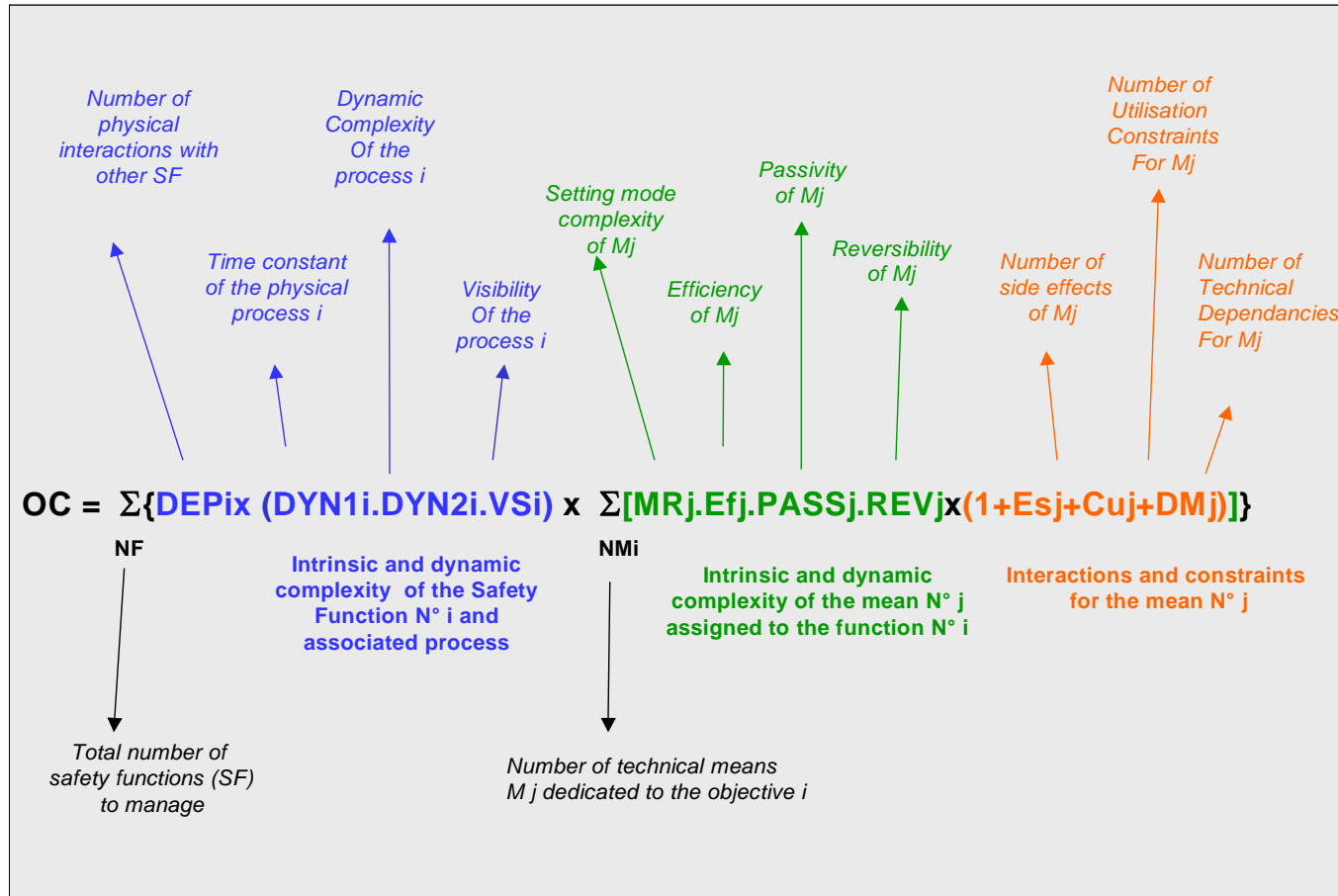

Quantification of complexity – Operational Complexity Index (OC)

Courtesy of CEA (France)

Design Strategies for innovative SMRs (3)

Operational complexity of the plant could be quantified (2)

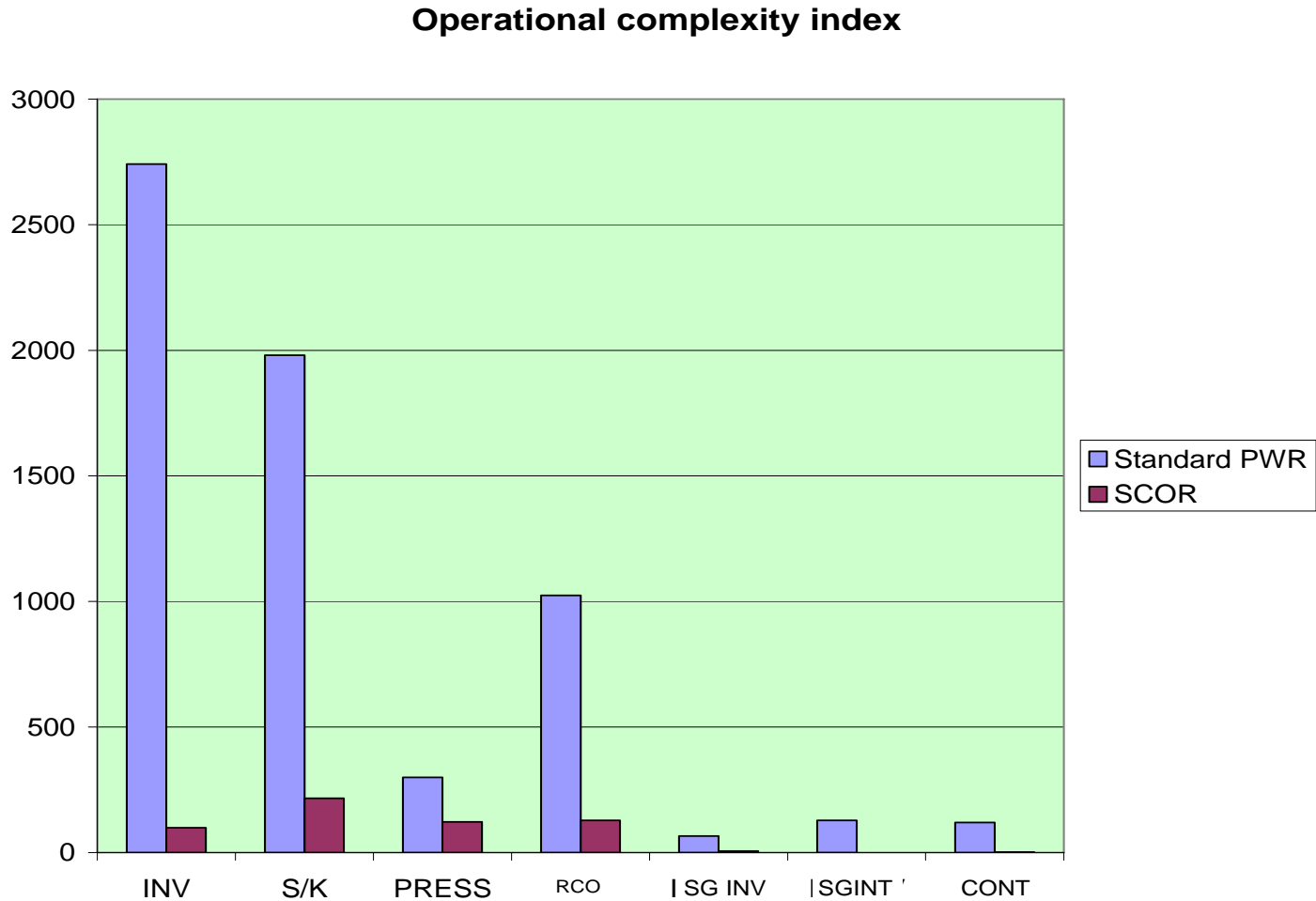

Operational complexity vs. safety functions for the integral design
SCOR and a standard PWR; CEA (France)

Design Strategies for innovative SMRs (4)

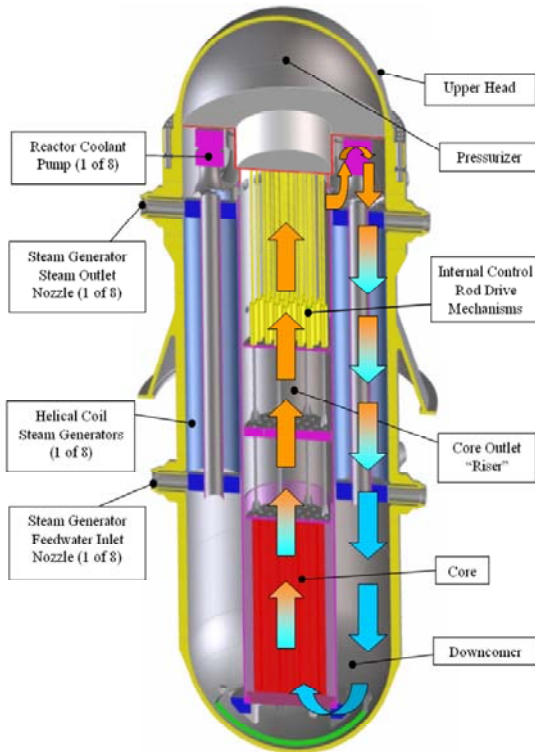

Integral design of IRIS (International team led by Westinghouse, USA)

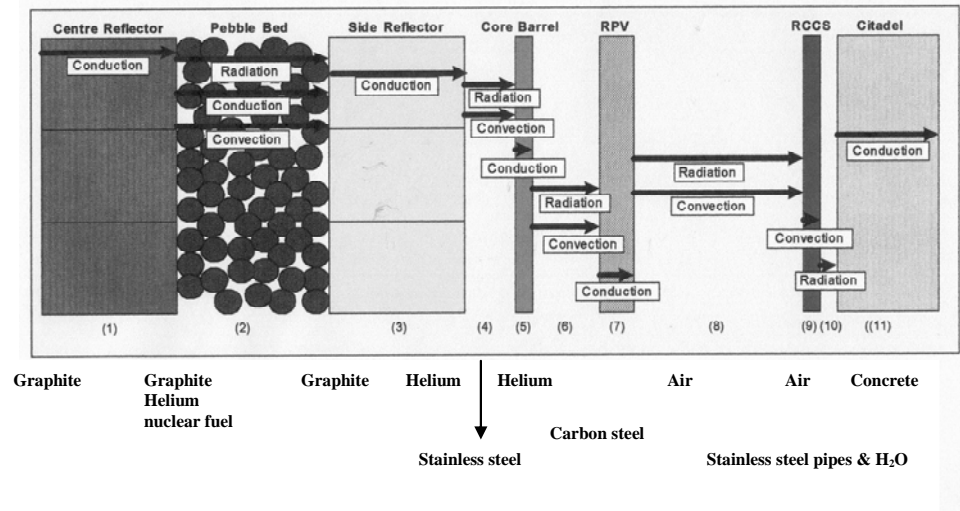

Passive heat removal paths of PBMR (PBMR Ltd., South Africa)

Design Strategies for Innovative SMRs (5)

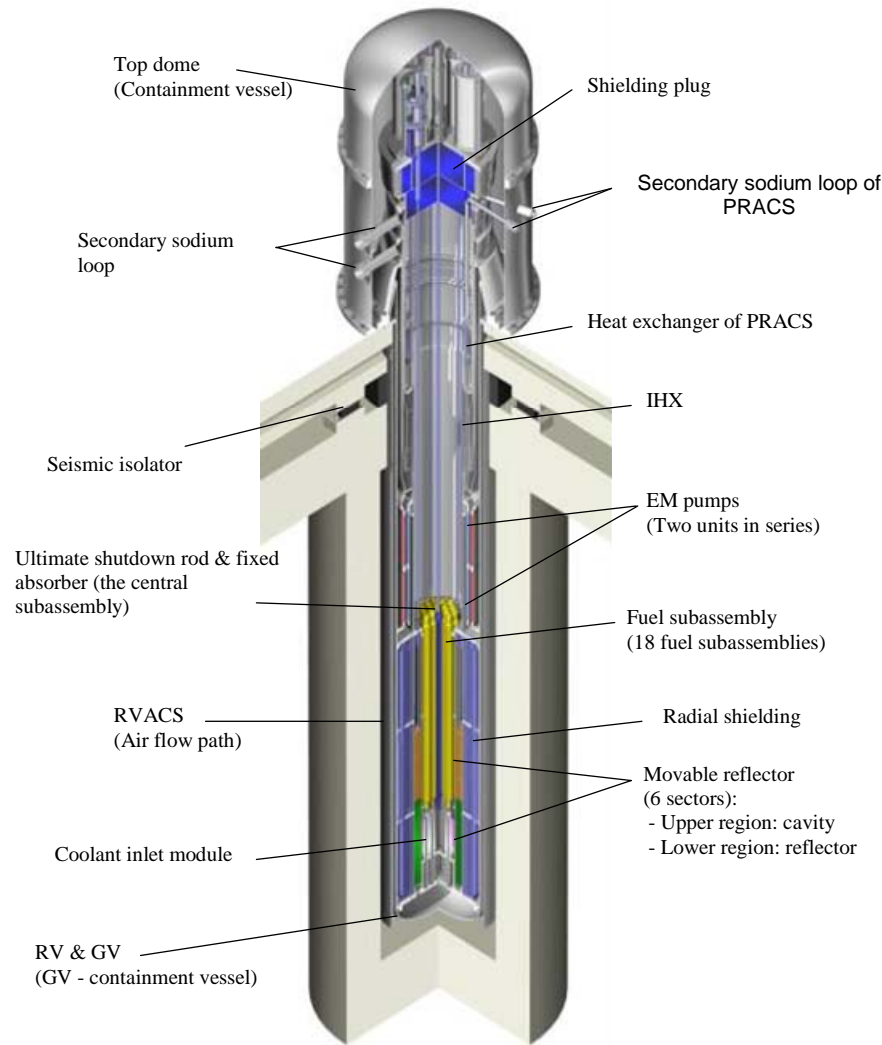

*4S sodium cooled reactor with a 10 – 30-year refuelling interval for a 50 MW(e) plant
(Toshiba – CRIEPI, Japan)*

Design Strategies for innovative SMRs (6)

➤ Borrowing from proven experience may facilitate early market penetration

- 1 Reactor
- 2 Steam generator
- 3 Main circulating pump
- 4 CPS drives
- 5 ECCS accumulator
- 6,7 Pressurizers
- 8 Steam lines
- 9 Localizing valves
- 10 Heat exchanger of purification and cooldown system

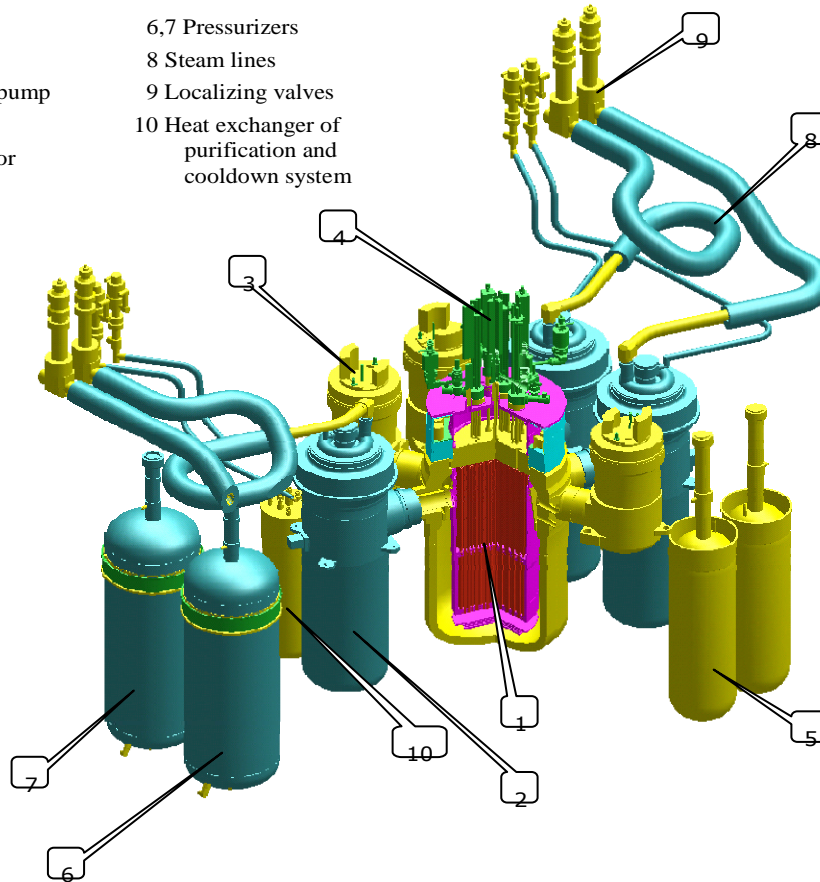

Modular layout of the KLT-40S reactor plant (OKBM, Russian Federation).

Design Strategies for innovative SMRs (7)

- **Increased energy conversion efficiency and use of reject heat for cogeneration reduce plant costs**

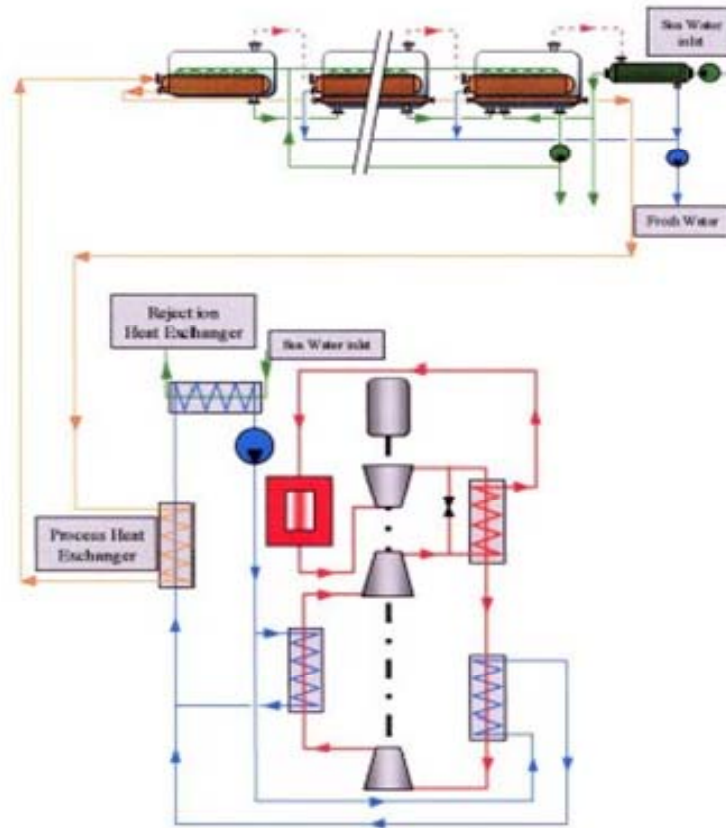

**GT-MHR Desalination Process Diagram, GA(USA)
– OKBM(Russia)
Targeted plant efficiency – 48%**

Design Strategies for innovative SMRs (8)

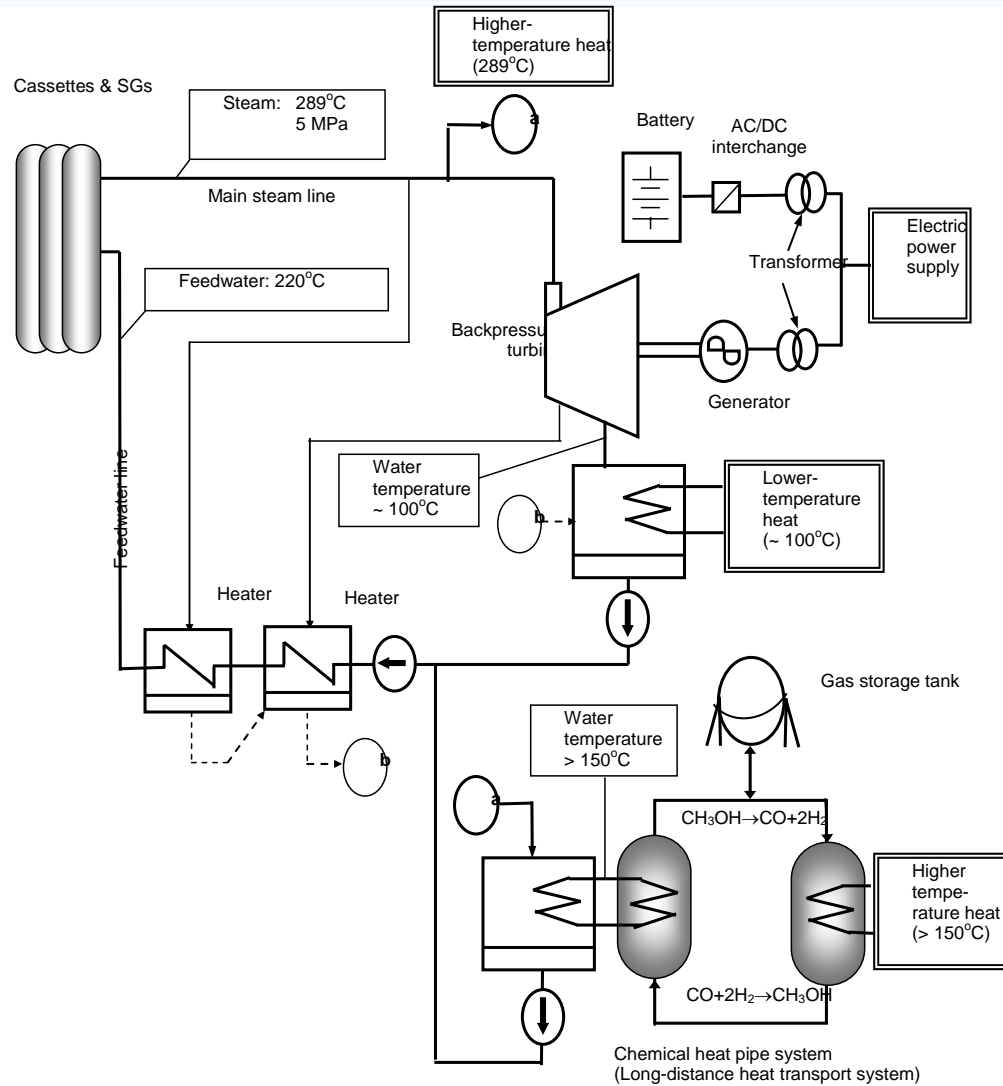

Energy supply system with the Package-Reactor (Hitachi-MHI, Japan)

Deployment Strategies (1)

Small reactor does not mean low-output NPP!

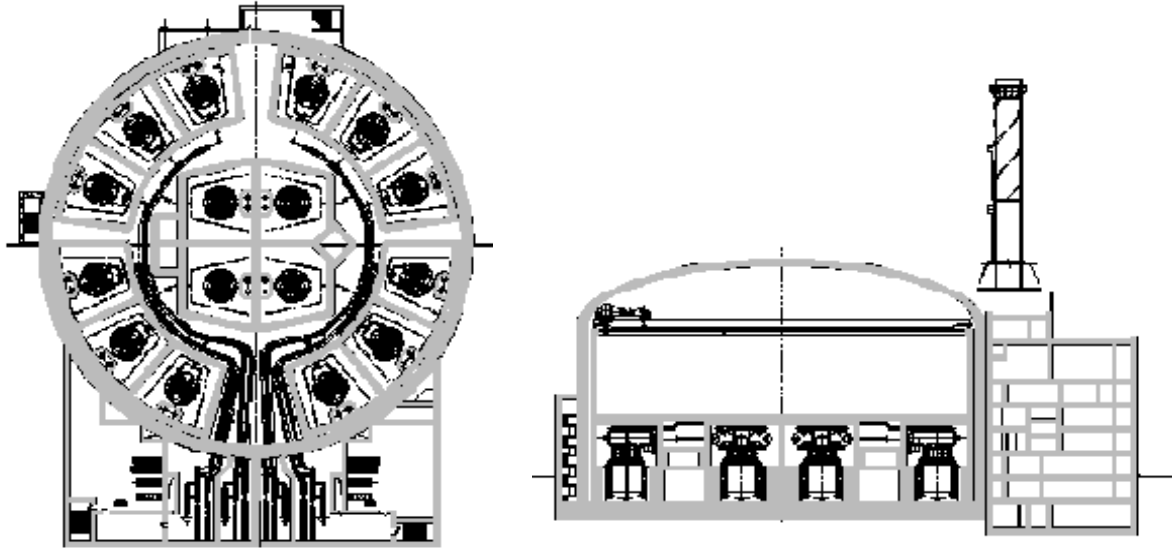

Clustered modular nuclear steam supply system SVBR-1600 with 16 SVBR-75/100 modules (IPPE-Gidropress, Russian Federation)

Potential for Smaller Reactor Economic Competitiveness (1) Westinghouse, USA

\$/kW (equivalent)

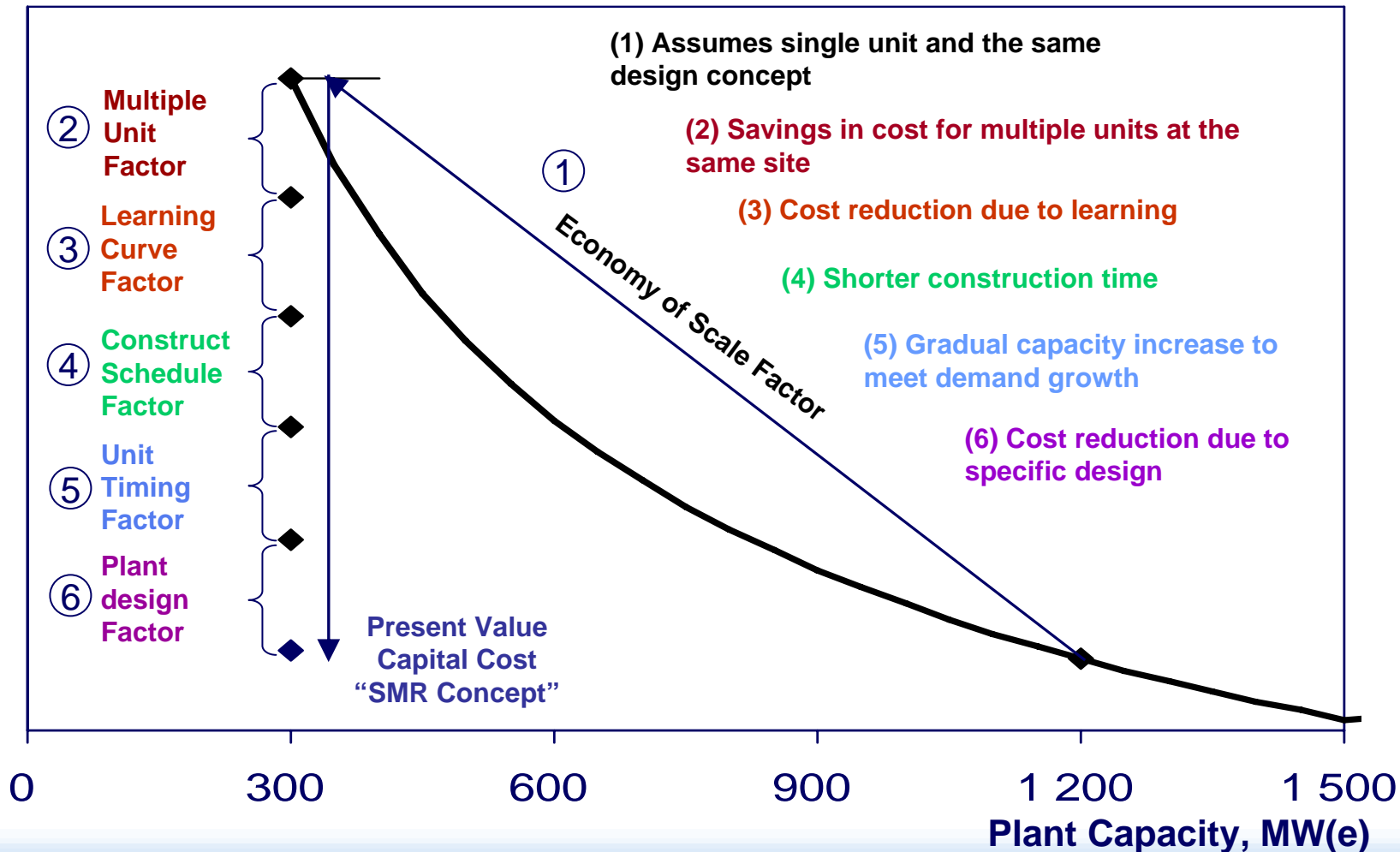

Potential for Smaller Reactor Economic Competitiveness (2)

SMR/Large Plant Comparison (Westinghouse, USA)

- *SMR: One 335 MW(e) plant, as part of four units*
- *Large: One single 1340 MW(e) plant*

Factor	SMR/Large Plan Capital Cost Factor Ratio	
	Individual	Cumulative
(1) Economy of scale	1.7	1.7
(2) Multiple units	0.86	1.46
(3) Learning	0.92	1.34
(4) (5) Construction schedule and timing	0.94	1.26
(6) Design specific	0.83	1.05

Deployment Strategies (2)

- *Incremental capacity increase reduces the required front end investment*

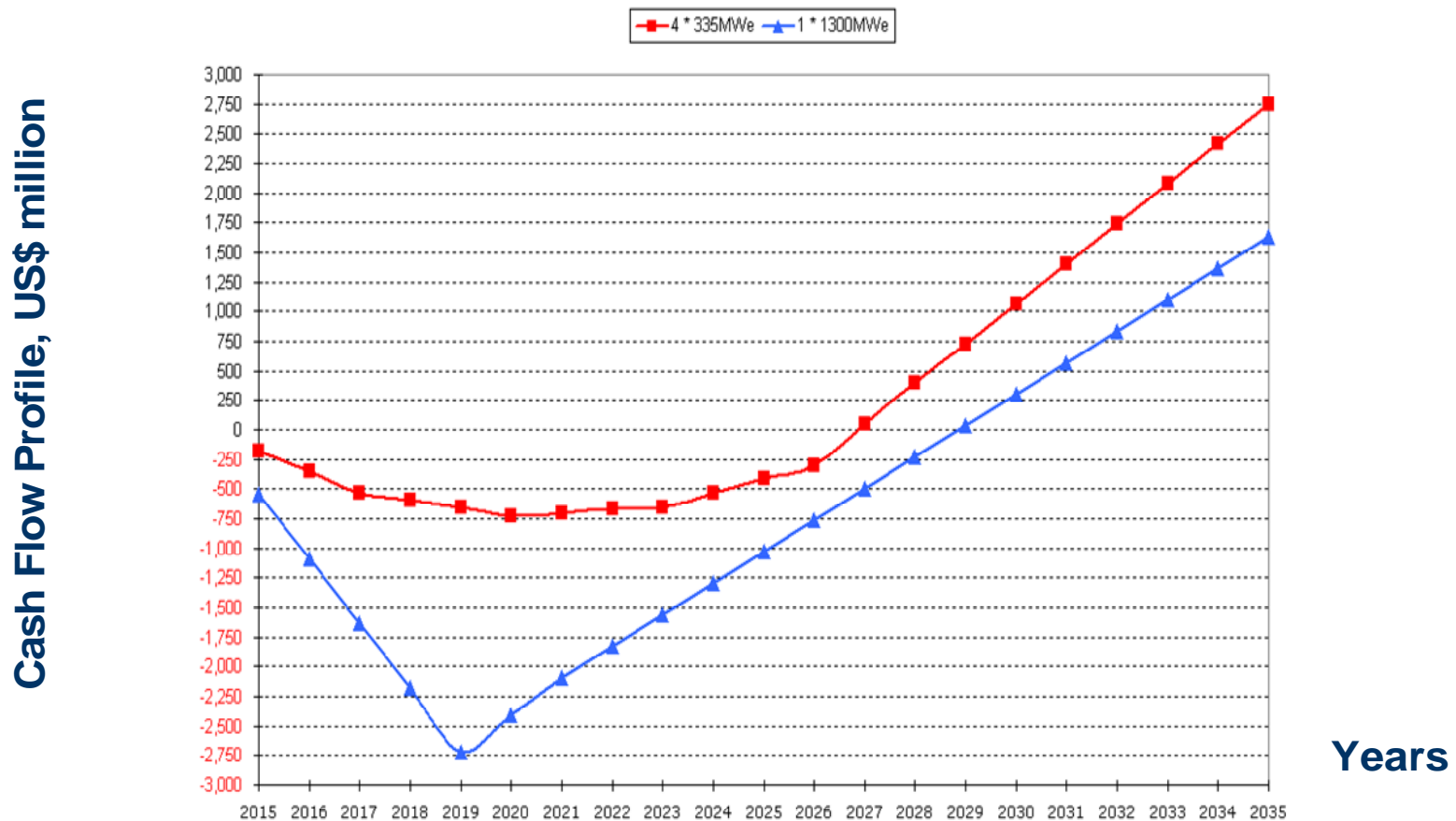

Cash flow profile for construction/ operation of four SMRs versus a single large plant (Westinghouse, USA)

Deployment Strategies (3)

➤ *Costs can be reduced through factory mass production in series*

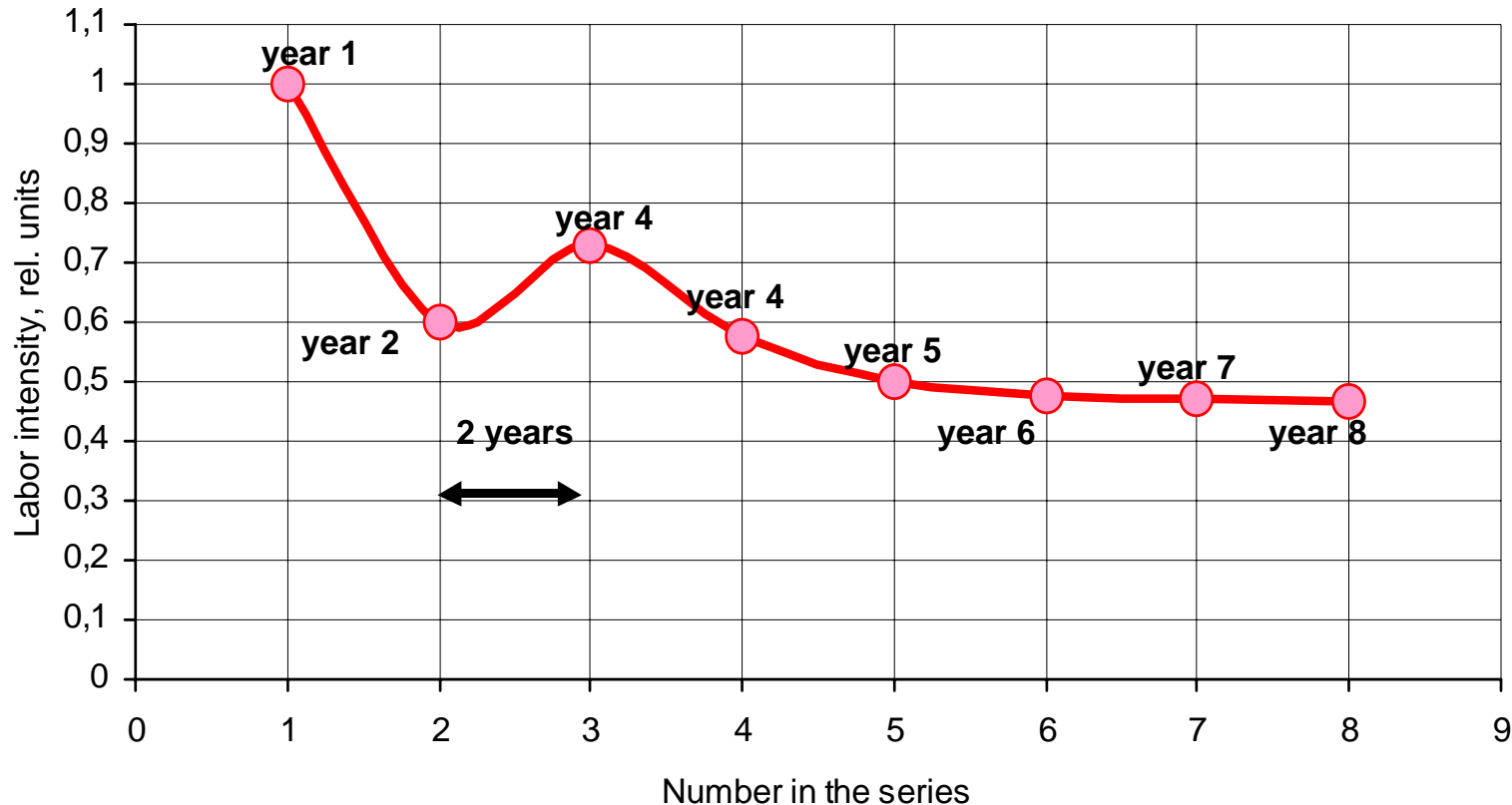

Production continuity vs. specific labour intensity in the production of marine propulsion reactors (OKBM, Russian Federation)

An Approach to Incorporate Increased Proliferation Resistance (1)

Small Reactors Without On-Site Refuelling (IAEA-TECDOC-1536, Jan. 2007)

- *SRWORs are reactors designed for infrequent replacement of well-contained fuel cassette(s) in a manner that impedes clandestine diversion of nuclear fuel material*
- Small reactors without on-site refuelling can be:
 - (a) *Factory fabricated and fuelled transportable reactors or*
 - (b) *Reactors with a once-at-a-time core reloading at a site performed by a external team that brings and takes away the core load and the refuelling equipment*
- No refuelling equipment and fuel storages at the site
- Increased refuelling interval (5 to 30+ years)

An Approach to Incorporate Increased Proliferation Resistance (2)

- Design approaches to ensure long-life core operation include:
 - ✓ *Reduced core power density;*
 - ✓ *Burnable absorbers (in thermal reactors);*
 - ✓ *High conversion ratio of the core (in fast reactors)*
 - ✓ *Refuelling performed without opening the reactor vessel cover*

- SRWORs end up at the same or less values of fuel burn-up and irradiation on the structures, achieved over a longer period than in conventional reactors

An Approach to Incorporate Increased Proliferation Resistance (3)

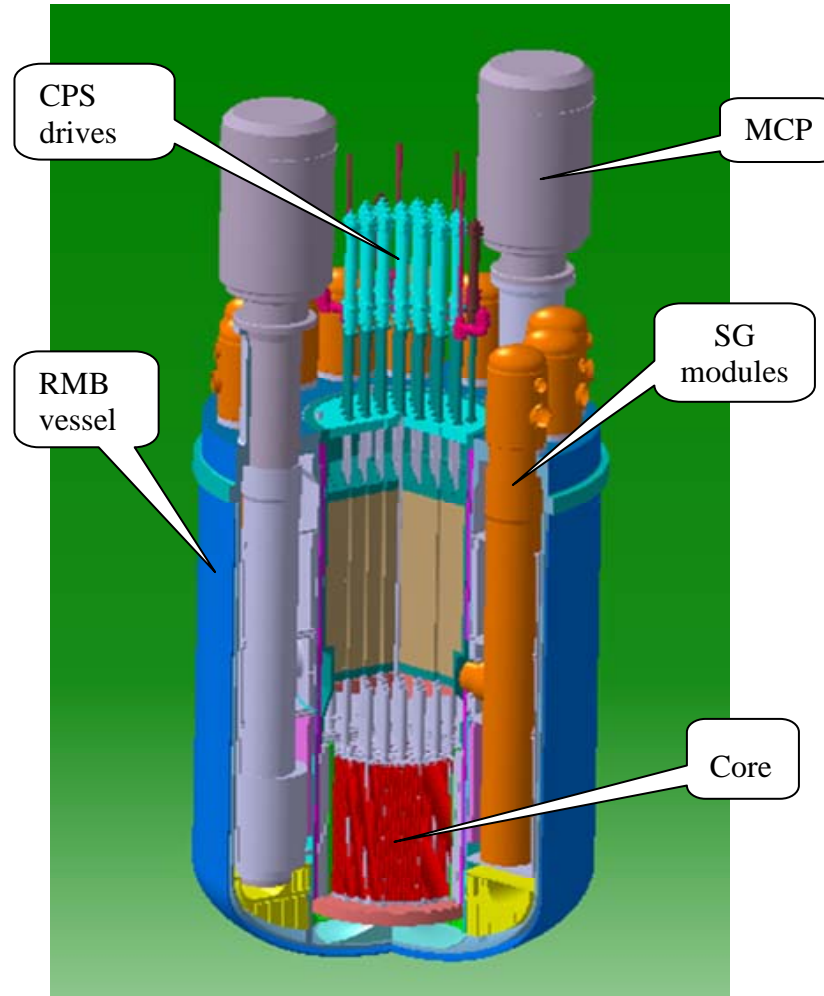

Pb-Bi cooled SVBR-75/100 reactor of 100 MW(e) with 6-9 EFY refuelling interval (IPPE-“Gidropress”, Russia)

An Approach to Incorporate Increased Proliferation Resistance (4)

Small Reactors without On-site Refuelling *could*:

- Relax the dependence on outsourced suppliers, fuel cost changes, political and economic tensions and conflicts between countries – *increase energy security*
- *Reduce the obligations for spent fuel and waste management*
- *Simplify decommissioning strategy*
- *Appear more environmentally clean, simple and secure*

Common challenges for innovative SMRs (1)

- *Adjust regulatory rules toward technology neutral and risk-informed approach*
- *Quantify reliability(?) of passive safety systems*
- *Justify reduced or eliminated EPZ (proximity to the users)*
- *Justify reliable operation with long refuelling interval (Licence-by-test + periodic safety checks)*
- ✓ *Demonstrate SMR competitiveness for different applications*

APSRA (BARC, India) - How it works ?

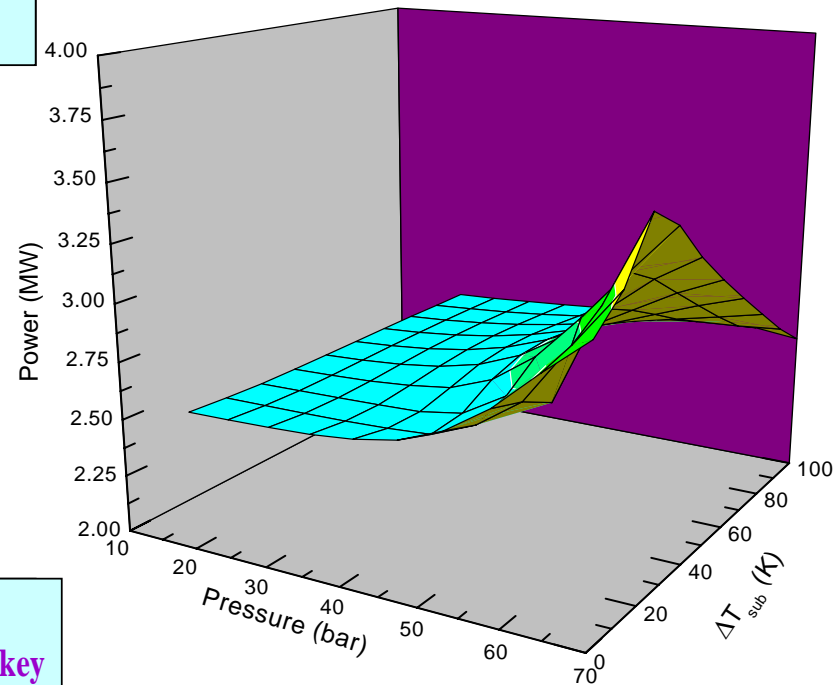
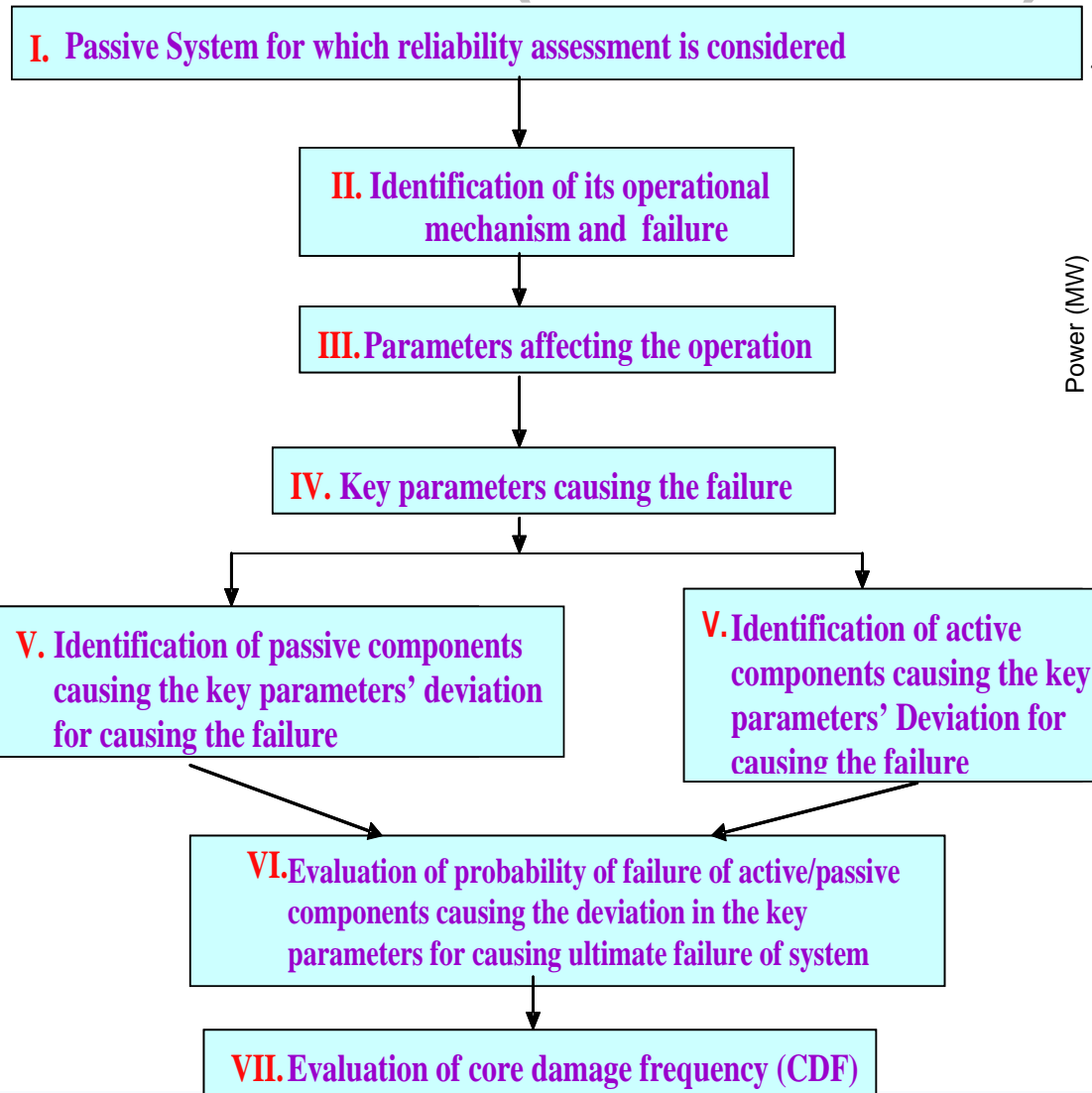

Typical Failure Surface for Natural Circulation

CONCLUSION

In the near term, most new nuclear power reactors are likely to be evolutionary large units.

But particularly in the event of a nuclear renaissance, the nuclear industry can expect an increasing diversity of customers, and thus an increasing number of customers with needs potentially best met by several or more of the innovative SMR designs now under development.

THANK YOU!

E-mail: v.v.kuznetsov@iaea.org

Publications planned for 2007-2008:

- ✓ NE Series Report “Review of Passive Safety Design Options for SMRs”
- ✓ NE Series Report “Approaches to Assess SMR Competitiveness”
- ✓ NE Series Report “Status of Validation and Testing of Passive Systems for Advanced Reactors”